



Pluto LNG Project **Treated Waste Water Management Plan**

Date: 05/09/11

Status: Rev 3

TABLE OF CONTENTS

EXECUTIVE SUMMARY	3
1. INTRODUCTION.....	4
1.1 Purpose	4
1.2 Scope.....	4
1.3 Description of Operator	4
1.4 Publication and Review Process	5
2. RE-USE AND DISPOSAL PHILOSOPHY.....	11
3. WASTEWATER COLLECTION, TREATMENT AND DISPOSAL	13
3.1 Site Water Production and Collection Systems.....	15
3.2 Treatment and Re-use Systems.....	17
3.3 Final Collection, Analysis and Disposal Systems	19
4. EXISTING ENVIRONMENT AT MUBRL DISCHARGE LOCATION	22
5. DISCHARGE MANAGEMENT	25
5.1 Management Plan Objectives	25
5.2 Multi-User Brine Return Line Outfall Zone - Environmental Values, Environmental Quality Objectives, Levels of Ecological Protection	26
5.3 Contaminants of Concern	31
6. MONITORING PROGRAM	33
6.1 Monitoring during Start-up and Commissioning	33
6.2 Monitoring during Ongoing Operations.....	34
6.3 Marine Monitoring	36
6.4 Whole Effluent Testing	36
7. PERFORMANCE REPORTING.....	40
7.1 Routine Reporting	40
7.2 Start-up and Commissioning Phase	40
7.3 Exception Reporting	40
7.4 Other Reporting.....	41
8. CONTINGENCY WASTEWATER MANAGEMENT PLAN	42
8.1 Contingency Management Options.....	42
8.2 Contingency Prioritisation	49
8.3 Outfall Modification.....	49
9. REFERENCES.....	51

EXECUTIVE SUMMARY

The Pluto LNG Project, for which Woodside is operator, is a significant investment in the development of Western Australia's gas reserves, in the generation of revenue for the country and the provision of one of the cleanest sources of fossil fuel based energy to meet world demand.

The procedures and protocols set out in this plan will ensure that water produced during the processing of hydrocarbons into LNG from the Pluto gas field is treated to a level suitable for ocean discharge. The plan is underpinned by a philosophy that seeks to maximise the opportunities for treated water to be re-used on site or provided to third parties and thus ocean discharge to be avoided. The plan documents how the State and Federal conditions of environmental approval of the project will be achieved and complies with the conditions of the approvals.

The plan, in conjunction with supporting information, outlines why the treatment and re-use systems installed at the Pluto LNG Project represents a best-in-class investment and are ideally positioned to achieve the objectives of re-using water as far as reasonably practicable, whilst ensuring a high level of ecological protection is maintained around the ocean outfall site.

The practical elements of the plan detail how discharges of treated water will be monitored, and the standards to which discharges must comply, to ensure the objectives are achieved. The discharge standards to be applied during the commissioning period are based on a set of ecological protection criteria derived from the Australian and New Zealand Environment and Conservation Council *Guidelines for Fresh and Marine Water Quality (2000)*. At the completion of commissioning, whole effluent toxicity testing of treated water will derive site and water-specific discharge standards that will be applied during operations. An ongoing programme of water quality monitoring throughout commissioning and operation of the water treatment plant, and regular repeats of the whole effluent toxicity programme for the life of the Pluto LNG Project, ensures the standards are both appropriate and being met.

A programme of routine and event-based performance reporting to the Department of Environment and Conservation is provided in the plan, which will enable the regulatory authorities to assess compliance with the plan and ensure the objectives of the plan are being achieved.

Recognising that even a robust treatment system such as the water treatment plant installed for the Pluto LNG Project may not always be able to achieve the stringent discharge criteria imposed, the plan also includes a comprehensive contingency plan. The contingency plan identifies a range of waste water management alternatives that can be implemented to ensure the objectives of the plan are still achieved, even when the waste water treatment plant is not operating as intended.

1. INTRODUCTION

1.1 Purpose

This Marine Treated Wastewater Discharge Management Plan (TWMP) has been developed to ensure that disposal of treated process wastewater from operation of the Pluto LNG Project, and stormwater runoff from process areas, is undertaken and managed in a way that reduces the environmental impacts to as low as reasonably practical (ALARP) and in accordance with the “Objectives” defined by the Minister in Ministerial Statement No. 757 (for the Pluto LNG Development).

The TWMP fulfils Condition 7-2 to 7-4 and 7-8 to 7-13 of Ministerial Statement No. 757. Table 1-1 provides a summary of how the plan fulfils each element of these conditions and provides a reference to the sections within the TWMP where each of these elements is addressed.

The TWMP also fulfils Condition 1(c)(iii) of Approval to Take a Controlled Action, EPBC2006/2968 (Commonwealth). Table 1-2 provides a summary of how the plan fulfils each element of this condition and provides a reference to the sections within the TWMP where each of these elements is addressed.

Appendix A provides a summary of how each of the remaining State Ministerial conditions relating to treated wastewater discharges from the facility (Conditions 7-1 and 7-5, 7-6 and 7-7) have been addressed, although these fall outside the scope of this plan.

1.2 Scope

To fulfil the requirements of both Ministerial Statement No. 757 and EPBC2006/2968, the scope of the TWMP includes treatment and disposal of water from the following sources:

- Water associated with raw gas withdrawn from the Pluto field (“produced water”); and
- Water collected from process equipment (e.g. hot water loops).

In addition, the following treated waste water streams (where these are to be discharged with the above waste water streams and thus may influence discharge water quality) within the scope of the TWMP include:

- Potentially contaminated stormwater runoff from process areas;
- Demineralised water, where the supply to the plant is sourced from the effluent treatment plant; and
- Domestic wastewater (treated sewage and grey water).

The TWMP does not include the management of water discharged from site as a result of small-scale water desalination (reject brine), demineralisation reject (where the feedstock is the desalination plant), water used for dust suppression on site or disposed of to land, clean stormwater run-off and water (from any source) that is free of contamination of risk to the environment. It also does not include any water used for future construction on the site, unless such water is directed through equipment (e.g. the effluent treatment plant or sewage treatment plant) covered by this plan.

1.3 Description of Operator

Woodside Burrup Pty Ltd, a wholly owned subsidiary of Woodside is operator of the Pluto LNG Project. References in this plan to “Woodside” may be references to Woodside Petroleum Ltd or its applicable subsidiaries.

Based in Perth, Western Australia (WA), Woodside has major operational assets and exploration and development interests in five continents including Australia and the United States. In 58 years Woodside has grown from a pioneer oil and gas explorer to Australia’s largest independent producer of oil and gas and one of the world’s largest producers of Liquefied Natural Gas (LNG).

Woodside operates one of Australia's largest resources projects, the North West Shelf Project in WA, which produces about 40% of Australia's oil and gas. In 2012 Woodside will be producing LNG from the Pluto LNG Project, near Karratha. Woodside is also seeking to progress the Sunrise LNG Development in the Timor Sea and the Browse LNG Development in northern WA.

Woodside Burrup Pty. Ltd. is the proponent for the Pluto LNG Project and is also operator, on behalf of itself and joint venture partners Tokyo Gas and Kansai Electric.

Further information about Woodside and the Pluto LNG Project can be found on <http://www.woodside.com.au>.

1.4 Publication and Review Process

The TWMP was first approved for implementation by the WA Minister for Environment on 18 March 2009 and was made publically available via Woodside's Pluto LNG Project website and at public access points as required by the CEO, Department of Environment (DEC). It is available electronically at:

<http://www.woodside.com.au/Our+Business/Projects/Pluto/Approval+Process/Environmental+Approval.htm>

This revision reflects the most up to date information regarding commissioning and operation of the waste water treatment and disposal facilities and follows issue by DEC of Works Approval W4466/2008/1 for the Pluto LNG Project Effluent Treatment Plant on 7 September 2009.

The TWMP will be reviewed by Woodside if at any stage a significant change to the waste water system is required during the life of the Pluto LNG Project. In addition, the TWMP requires an adaptive testing and management regime to be implemented, in regular consultation with the Department of Environment and Conservation via the Licensing process under Part V of the *Environmental Protection Act 1986*. This adaptive management regime requires the results of annual WET testing and compositional analysis (refer Section 5.3 and 6.4) to be considered when confirming the discharge specifications for the following twelve month period (draft specifications included as Appendix C).

The plan may also require revision at any time if required to reflect a change in regulatory conditions (e.g. following amendment to a Works Approval or Licence under Part V of the *Environmental Protection Act 1986* (EP Act)) to ensure the plan remains current. The contingency arrangements (Section 8) may also be reviewed and revised at the request of the CEO of DEC, as per Condition 7-12 of Ministerial Statement No. 757.

If changes are required to be made to the plan that are material to the risk presented by the operation of the facilities, a revised plan will be provided to the DEC and Department for Sustainability, Environment, Water, Population and Communities (SEWPC) for approval. Approval will be obtained prior to implementation of the revised plan and the revised plan will be made publically available to the prescribed requirements of the CEO of DEC.

Table 1-1 Cross Reference of the TWMP with Ministerial Statement No. 757 Condition 7-2 to 7-4 and Conditions 7-8 to 7-13

Deepwater Marine Outfall Conditions under Ministerial Statement No. 757		Current Status	TWMP Section
7-2	<p>Prior to construction of the wastewater treatment plant or the marine outfall, whichever is the sooner, the proponent, in consultation with Department of Environment and Conservation, shall prepare a Marine Treated Wastewater Discharge Management Plan to the requirements of the Minister for the Environment on advice of the Environmental Protection Authority.</p> <p>The objective of this Plan is to ensure that the discharge of treated wastewater is managed to achieve simultaneously the following Environmental Quality Objectives as described in the document, <i>Pilbara Coastal Water Quality Consultation Outcomes: Environmental Values and Environmental Quality Objectives</i> (Department of Environment, March 2006):</p> <ul style="list-style-type: none"> • Maintenance of ecosystem integrity with spatially-assigned levels of protection; • Maintenance of aquatic life for human consumption assigned to all parts of the marine environment surrounding the ocean outlet; • Maintenance of primary contact recreation values assigned to all parts of the marine environment surrounding the ocean outlet; • Maintenance of secondary contact recreation values assigned to all parts of the marine environment surrounding the ocean outlet; • Maintenance of aesthetic values assigned to all parts of the marine environment surrounding the ocean outlet; • Maintenance of cultural and spiritual values assigned to all parts of the marine environment surrounding the ocean outlet; and • Maintenance of Industrial Water Supply. <p>This Plan shall address the following:</p>	<p>This document fulfils the requirements of the Marine Treated Wastewater Discharge Management Plan. The document was approved by the Minister on 18 March 2009 on the advice of the Environmental Protection Authority (EPA) prior to the construction of the waste water treatment plant.</p> <p>Upstream of the water treatment plant itself, Woodside has taken decisions relating to water production and pre-treatment that optimise potential for re-use, including MEG regeneration whereby entrained salts from the reservoir are separated from the water stream and managed as solid waste.</p> <p>Water treatment and recovery technology installed is considered best practice, incorporating advanced water treatment equipment and processes capable of achieving a high degree of re-use and the stringent discharge objectives prescribed by the Minister.</p> <p>Following agreement that either a deep ocean outfall or a zero-discharge solution was an unfeasible solution for this facility, Woodside was directed by the EPA to use the Water Corporation Multi-User Brine Return Line (MUBRL) as the outfall for any treated waste water discharging to sea.</p>	<p>Section 2 (Reuse and Disposal Philosophy); Section 3 (Collection and Treatment); Section 5 (Discharge Management); and Section 8 (Contingency Plan).</p>
7-2 (1)	<p>Determination of the effect of wastewater flow rate on the number of dilutions the diffuser is predicted to achieve within the zone of initial dilution at maximum flow rate;</p>	<p>Water Corporation modelling determined that the MUBRL achieves an initial dilution ratio of 86:1 within the approved mixing zone. This has been used as the basis for this plan. The treated waste water discharged from the Pluto LNG Project via the MUBRL represents only a very small</p>	<p>Section 3.3.2</p>

This document is protected by copyright. No part of this document may be reproduced, adapted, transmitted, or stored in any form by any process (electronic or otherwise) without the specific written consent of Woodside. All rights are reserved.

Deepwater Marine Outfall Conditions under Ministerial Statement No. 757		Current Status	TWMP Section
		(usually less than 1%) fraction of the MUBRL flow and thus modelling of dispersion of effluent from the Pluto LNG Project on this is, in most instances, highly conservative.	
7-2 (2)	Setting of environmental values, environmental quality objectives and levels of ecological protection to be achieved around the outfall;	Consistent with the <i>Pilbara Coastal Water Quality Consultation Outcomes : Environmental Values and Environmental Quality Objectives, March 2006</i> , a “low” level of ecological protection level is applied within the small initial dilution zone (or “mixing zone”) and a “high” level of protection is targeted outside of this zone. The mixing zone is as defined for the MUBRL.	Section 5 (Discharge Management)
7-2 (3)	Identification of a range of feasible and practical management options and the environmental quality indicators and associated “trigger” levels for the implementation of remedial, management and/or preventative actions to protect the water quality and the marine environment based on the guidelines and recommended approaches in ANZECC/ARMCANZ (2000);	<p>Feasible and practical management options have been explored and incorporated into the final design. The plant and equipment installed to extract water from the raw gas from the Pluto field and treat produced water results in the highest practicable opportunity for water re-use and represents “beyond best practice” with regard to treatment and resource recovery, as recovery equipment and operating costs will not be paid back through savings made by reductions in third party water supply costs.</p> <p>Levels of ecological protection have been defined around the outfall. A series of environmental quality indicators and associated “trigger levels” for response have been prescribed. These align with the recommended approaches in ANZECC/ARMCANZ (2000).</p> <p>The responses following the various trigger levels being reached or exceeded are also documented.</p>	Section 2 (Reuse and Disposal Philosophy); Section 3 (Collection and Treatment); Section 5 (Discharge Management); and Section 8 (Contingency Plan).
7-2 (4)	Whole Effluent Toxicity (WET) testing of wastewater, consistent with ANZECC requirements, and addressing the items in Schedule 5 (attached);	WET testing in accordance with ANZECC/ARMCANZ (2000) will be carried out routinely. The WET testing methodology is included within this plan. The requirements of Ministerial Statement 757 Schedule 5 and further correspondence with the Department of Environment and Conservation are incorporated within both the WET testing methodology and timeframes for implementation of WET testing.	Section 6
7-2 (5)	Redesign and incorporation of a new diffuser, including timelines, in the event that the WET testing results show that the original wastewater diffuser is not achieving sufficient dilutions to meet a high level of ecological protection at the edge of the mixing zone;	<p>The direction to use the Water Corporation MUBRL given to Woodside by EPA means the dilution ratio of 86:1 has been used as the basis for water treatment design, impact assessment, approval and as the basis for this plan going forward.</p> <p>Commitments from Water Corporation to review and, if required, improve dilution and mixing through the MUBRL outfall are documented.</p>	Section 8 (Contingency Plan).

This document is protected by copyright. No part of this document may be reproduced, adapted, transmitted, or stored in any form by any process (electronic or otherwise) without the specific written consent of Woodside. All rights are reserved.

Deepwater Marine Outfall Conditions under Ministerial Statement No. 757		Current Status	TWMP Section
7-2 (6)	Verification of diffuser performance in terms of achieving the required number of initial dilutions under low energy/calm meteorological and sea-state conditions to achieve a high level of ecosystem protection (99% species protection) at the edge of the approved mixing zone;	Diffuser performance has been verified by the Water Corporation, and as such this plan refers to the data available from Water Corporation.	Section 3.3.2
7-2 (7)	A monitoring program to permit determination of whether the water quality objectives are being met; and	A monitoring programme focussed on the effluent discharged to the MUBRL is included within this plan. Monitoring of the receiving environment is conducted on behalf of the MUBRL users by the Water Corporation and results are provided to the DEC as required by the MUBRL Ministerial Statement 594. Monitoring of effluent prior to release into the MUBRL is also included, to ensure that effluent is appropriate for release.	Section 6 (Monitoring)
7-2 (8)	Protocols and schedules for reporting performance against the Environmental Quality Objectives using the environmental quality trigger levels.	The plan includes protocols and schedules for reporting performance (as determined by the monitoring programme covered by 7-2 (7)).	Section 7 (Reporting)
7-3	The proponent shall implement the Marine Treated Wastewater Discharge Management Plan required by condition 7-2.	The plan will be implemented at all stages of operation of waste water treatment and disposal facilities. The plan includes a number of monitoring and reporting requirements that provide transparency to external stakeholders that the plan is being implemented and objectives are being achieved. During commissioning, an Effluent Treatment Plant Commissioning Plan will also be implemented, to assist in the start-up, commissioning and initial testing of the facilities, as required under Works Approval W4466/2008/1 Condition 3. In accordance with the condition, the plan includes: <ul style="list-style-type: none"> • A description of commissioning activities, including the proposed timing and duration of commissioning activities; • Monitoring regime of effluent; • Disposal options for effluent (based on effluent monitoring quality); and • Contingency plan for effluent disposal. 	Section 6 (Monitoring) and Section 7 (Reporting)
7-4	The proponent shall make the Marine Treated Wastewater Discharge Management Plan required by condition 7-2 publicly available in a manner approved by the CEO.	The latest approved version of the TWMP is available on the Pluto LNG Project website (refer Section 1.4). If a revised plan is approved by the Minister, the revised plan will be made public as per the instructions of the CEO of DEC.	Section 1.4

This document is protected by copyright. No part of this document may be reproduced, adapted, transmitted, or stored in any form by any process (electronic or otherwise) without the specific written consent of Woodside. All rights are reserved.

Deepwater Marine Outfall Conditions under Ministerial Statement No. 757		Current Status	TWMP Section
7-8	Within three months following commissioning and stabilising of plant operations, the proponent shall conduct an analysis of effluent properties and contaminant concentrations, to an analytical limit of reporting agreed by the Department of Environment and Conservation, demonstrating that they are substantially consistent with predictions.	Testing procedures, parameters (analytical limits), the timeframes for testing, analysis and reporting are included within this plan.	Section 6 (Monitoring) and Section 7 (Reporting)
7-9	Prior to operation, the proponent shall develop a Contingency Wastewater Management Plan which considers alternate options for wastewater disposal in the event that the Environmental Quality Objectives are not met as determined through Whole Effluent Toxicity testing, diffuser performance monitoring or environmental quality monitoring, to the requirements of the Minister for the Environment.	A plan for the management of waste water in the event that the Environmental Quality Objectives are not able to be met as determined through Whole Effluent Testing, diffuser performance monitoring or environmental quality monitoring, or in the event that the treatment plant mal-functions, has been included within this plan.	Section 8 (Contingency Plan)
7-10	In the event that the treatment plant malfunctions or goes off-line, the proponent shall include within the Contingency Wastewater Management Plan required by condition 7-9 alternative options for wastewater disposal to the timing and other requirements of the Minister for the Environment.	This plan sets out a regime for testing of effluent and management if testing shows that waste water is outside of the discharge specification. This may be due to a number of reasons, including malfunction of the treatment plant.	Section 8 (Contingency Plan)
7-11	In the event that the Environmental Quality Objectives are not being met, the proponent shall implement the Contingency Wastewater Management Plan required by condition 7-9.	The contingency plan will be implemented if the conditions for implementation are met. The mechanisms triggering the plan are set out within the plan.	Section 8 (Contingency Plan).
7-12	The proponent shall review and revise the Contingency Wastewater Management Plan required by condition 7-9, as and when directed by the CEO.	A process to review and revise this plan (which incorporates the Contingency Wastewater Management Plan) on a regular basis and/or at the direction of the CEO, DEC, is detailed within this plan.	Section 1.4
7-13	The proponent shall make any revisions of the Contingency Wastewater Management Plan, as required by condition 7-12, publicly available in a manner approved by the CEO.	The latest approved version of the TWMP (including the Contingency Wastewater Management Plan) is available on the Pluto LNG Project website. If a revised plan is prepared upon the direction of the CEO of DEC and subsequently approved by the Minister, the revised plan will be made public as per the direction of the CEO, DEC.	Section 1.4

This document is protected by copyright. No part of this document may be reproduced, adapted, transmitted, or stored in any form by any process (electronic or otherwise) without the specific written consent of Woodside. All rights are reserved.

Table 1-2 Cross Reference of the TWMP with EPBC2006/2968 Condition 1(c)(iii)

Deepwater Marine Outfall Conditions under Ministerial Statement No. 757		Current Status	TWMP Section
1(c)(iii)	The person taking the action must submit, for the approval of the Minister, a plan (or plans) for managing the offshore impacts of the action. The plan (or plans) must include measures for:	This plan addresses this condition.	
	the monitoring and disposal of produced water (PW), including the analysis of expected PW chemistry,	Disposal is via the MUBRL where re-use can not be achieved, or as otherwise stated (i.e. within the Contingency Plan). Analysis of expected treated PW and other effluent chemistry is provided.	Section 5.2.1
	baseline biological and physical information at the PW outfall site,	Baseline information is available from Water Corporation and a summary is provided.	Section 4 (Existing Environment)
	toxic impacts of PW on marine flora and fauna based on ecotoxicological, bioaccumulation and biodegradation studies,	ANZECC/ARMCANZ (2000) has been used as directed by the State Environment Minister as the basis for assessing likely impacts and setting initial discharge criteria. A programme of monitoring and toxicological testing is set out in the plan to provide a more robust analysis of the potential for impact and determine site-specific discharge criteria.	Section 5.2.1 and Section 6 (Monitoring)
	industry best practice disposal of PW,	Re-use, treatment and disposal options are detailed, which substantiate Woodside's position that the proposed solution is industry best practice.	Section 2 (re-use and Disposal Philosophy) and 3 (Treatment and Disposal)
	monitoring and reporting of biological and physical indicators, and	A monitoring and reporting regime covering physical indicators is included within the plan. A summary of the ongoing biological monitoring conducted by Water Corporation as manager of the MUBRL is included to address biological monitoring requirements.	Section 6 (Monitoring) and Section 7 (Performance Reporting)
	contingency measures if adverse impacts are indicated.	A contingency plan has been included that will be implemented where the initial discharge specification can not be achieved.	Section 8 (Contingency Waste Water Management Plan)

This document is protected by copyright. No part of this document may be reproduced, adapted, transmitted, or stored in any form by any process (electronic or otherwise) without the specific written consent of Woodside. All rights are reserved.

2. RE-USE AND DISPOSAL PHILOSOPHY

Throughout the Pluto LNG Project environmental assessment process, both State and Commonwealth regulators advised that wastewater discharges to Mermaid Sound should be avoided if practicable and options for reuse should be taken up, in preference to marine discharge (refer to Environmental Protection Authority (EPA) Bulletin 1259).

As a consequence, various water recovery studies and re-use options have been assessed by Woodside (FWW 2006, FWW 2008). The key outcome of these investigations included:

- Optimisation of water influent contaminant levels, to maximise the potential for on-site reuse (and, as a consequence, maximise the end quality of treated wastewater); and
- Inclusion of extensive treatment systems for all process and process area stormwater streams to meet plant service water specifications.

This enables extensive reuse of treated wastewater within the Pluto LNG plant, which in turn should result in substantially reduced surplus volume requiring disposal.

However, water balance studies indicate that treated effluent will at times be in excess of on-site service water demand. Thus, “zero discharge” is impractical without the identification and implementation of viable alternative considering other disposal options.

Initial discussions between Woodside and third parties on the potential market for Pluto's excess treated reuse water indicated appetite exists for treated industrial waste water. However, third parties indicated that at present there was insufficient water available on a reliable/predictable supply basis to justify the cost of infrastructure (pumps, pipes and storage) to transfer water to these third party users. In the short to medium term the Pluto facilities are expected to utilise a high proportion of the normal treated water production rate. Volumes in excess of the Pluto site requirements are therefore only expected to be available on an infrequent basis, primarily associated with storm events, high water production periods or low water use periods. Therefore, given the uncertainty associated with volumes that could be made available for third party reuse, viable options for third party re-use of any surplus treated water are currently unable to be identified.

As the Pluto field ages, produced water quantities are expected to increase and may result in reuse water quantities that consistently exceed Pluto site service water requirements. Woodside will explore opportunities for third party re-use if internal water requirements are consistently being exceeded.

Discharge to ocean needs to be retained to provide a disposal route for infrequent volumes of excess treated effluent from both the effluent treatment plant (when supply exceeds re-use requirements or the re-use specification can not be achieved) and sewage treatment plant (when on-site irrigation can not be used).

Options for ocean discharge considered (Woodside 2008) included:

1. Discharge into water of depth greater than 30 m outside the Dampier Archipelago,
2. Discharge via a purpose built diffuser located at the end of the Pluto export jetty, and
3. Discharge into Water Corporation's existing multi-user brine return line (MUBRL) with outfall located in King Bay.

Option 2 was included as the base case in the Pluto LNG Project Public Environment Review / Public Environment Report (PER); however following further discussion with the regulator (refer EPA Bulletin 1259), Option 3 was also taken forward for detailed consideration. Discharge to the Water Corporation's existing MUBRL was adopted as the preferred approach based on environmental grounds and regulator preference as:

- The outfall infrastructure has been installed and the outfall and mixing zone is already operating (refer to Ministerial Statement 594); and

This document is protected by copyright. No part of this document may be reproduced, adapted, transmitted, or stored in any form by any process (electronic or otherwise) without the specific written consent of Woodside. All rights are reserved.

- The outfall has sufficient line capacity to receive surplus treated effluent from the Pluto LNG Project.

Option 1 would have involved construction of a pipeline on the seabed, approximately 30 km long. This option was eliminated from further assessment due to potential seabed and coral impacts associated with pipeline construction, capital expenditure (estimated to be in excess of \$50 million) and the operational costs and technical challenges associated with pumping, maintenance and repair, where viable and environmentally sound alternatives existed. In addition, the water extraction and treatment equipment has been designed to maximise the reuse of wastewater as plant service water. Hence, a deep water ocean outfall to discharge a small, non-routine surplus of highly treated process waste water is not consistent with sound environmental management.

3. WASTEWATER COLLECTION, TREATMENT AND DISPOSAL

Site systems managing water streams covered by this plan can be broadly described by the following categories:

- Production and collection systems;
- Treatment and re-use systems; and
- Disposal systems.

These are explained in further detail in Sections 3.1 to 3.3 respectively. An overview of the full production, collection, treatment, re-use and disposal system for LNG plant wastewater streams for the Pluto LNG Project is provided as Figure 3-1.

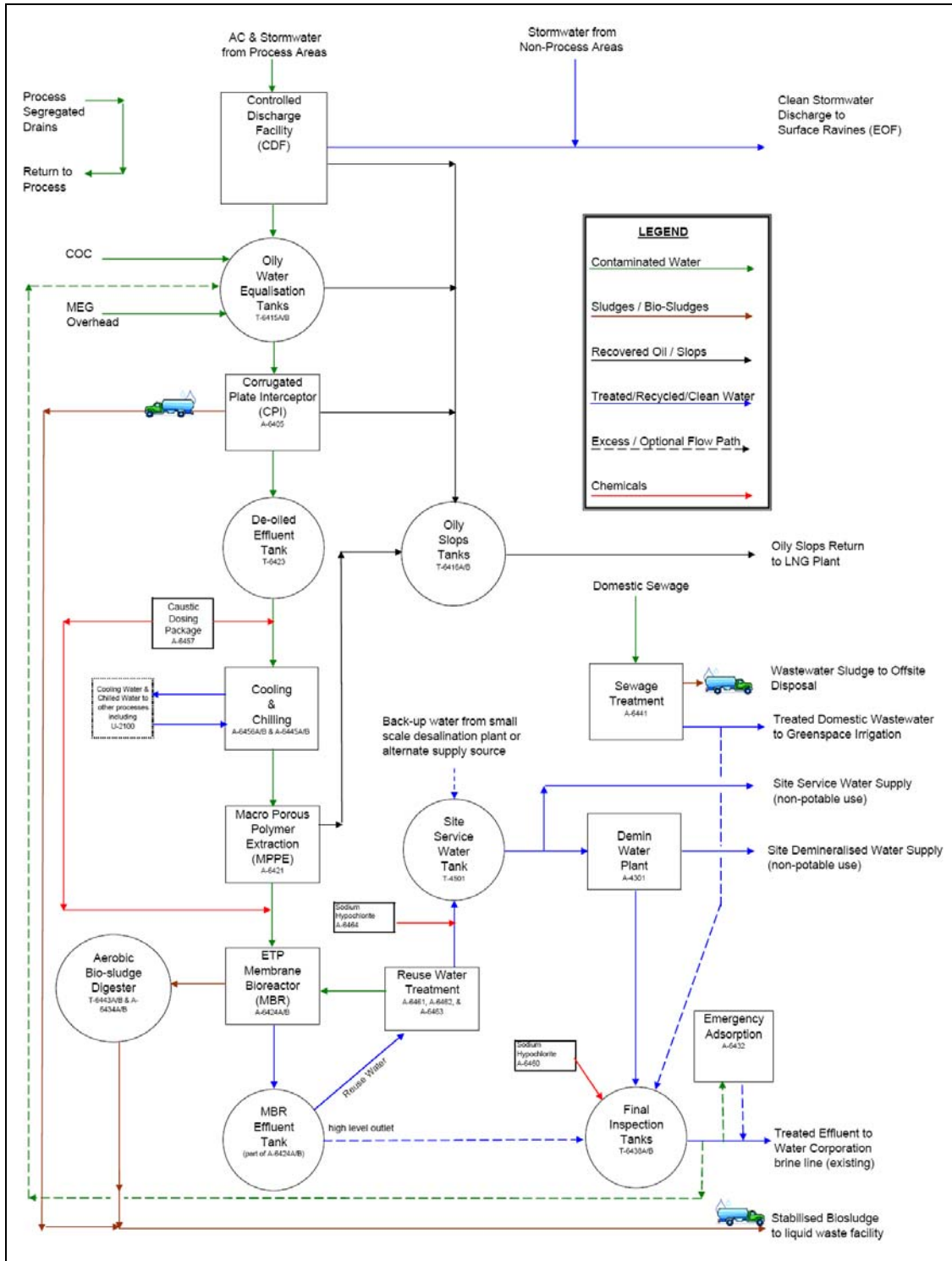

Figure 3-1 Water System Overview

This document is protected by copyright. No part of this document may be reproduced, adapted, transmitted, or stored in any form by any process (electronic or otherwise) without the specific written consent of Woodside. All rights are reserved.

3.1 Site Water Production and Collection Systems

3.1.1 Systems Integral to the TWMP

Collection and drainage systems are provided within the LNG plant footprint to ensure the segregation of process wastewater and potentially contaminated stormwater and allow direction of each stream to appropriate treatment and/or disposal facilities.

The effluent streams and collection systems that form part of the TWMP are described in the following paragraphs below and are made up of:

- An accidentally contaminated collection system;
- A continuously oil-contaminated collection system; and
- A produced water extraction system.

Accidentally Contaminated (AC)

The AC system collects surface water run-off by means of a network of surface drain channels and liquid filled underground pipe headers, which discharge runoff under gravity to the Controlled Discharge Facility (CDF). AC drainage areas are considered to be areas in which chemical contamination of water is not expected to occur during normal operation, but which is at risk of accidental contamination with oil or other contaminants as a result of spills or leaks from equipment.

Accidental spillages shall be contained by kerbs or floor slopes in the process areas and bunds for storage tank areas. AC areas are sized to limit ingress of rain and designed to prevent overflow to surrounding areas. Implementation of the site spill response procedure will ensure immediate clean-up of any identified spillages to AC surfaces and maintain clean kerbed and bunded areas. Once collected in the CDF, AC water will be tested and either forwarded for treatment if contaminated, or released to the environment if not contaminated.

In heavy or prolonged rainfall events, excess water beyond the capacity of the CDF will bypass the CDF and be directed to natural drainage lines.

Continuously Oil Contaminated (COC)

The COC drainage system collects any oily leakages from equipment in localised kerbs, drip trays, drain trays, funnels, etc. Collected COC effluent is directed (via vacuum tanker or direct pumping) to the oily water equalisation tanks within the effluent treatment plant (ETP) for treatment. COC sources include equipment or packages with a higher potential for lubrication oil leakage (e.g. pumps, gearbox, compressor skids and hydraulic packages) and the jetty head (condensate loading arm).

Produced Water (PW)

PW generated as a result of refining Pluto reservoir fluids into gas and condensate primarily consists of condensed water with a small amount of formation water. Condensed water production rates are expected to be relatively consistent; as this water is directly related to the reservoir temperature and water that exists as vapour within the reservoir. Formation water however is expected to increase in volume as the wellfield ages and may be produced in higher volumes for short periods as the reservoir depletes. Total volumes of formation water are limited by the capacity of the hydrate inhibition system.

PW is carried to shore through the offshore pipelines and will be carried onshore within a multiphase mixture of hydrocarbon gas, condensate and mono-ethylene glycol (MEG). Onshore, MEG and water is separated from the hydrocarbon gas and condensate in the slug catcher and the MEG and water phase sent to the MEG regeneration system.

Any water still within the hydrocarbon stream will be removed via a multi-bed molecular sieve dehydration unit, which uses porous beads to trap and extract water from the hydrocarbons. Once a bed is saturated with water, the unit switches to another bed and the saturated bed is dried and readied again for use. Water is removed and reused within the process system.

The MEG regeneration system is a distillation unit, using heat to distill MEG from water and regenerate the MEG for re-use. The aqueous vapour phase produced by the MEG distillation process shall be condensed to produce, effectively, distilled water with some carry-over MEG and benzene, toluene, ethyl benzene and xylene (BTEX). This is pumped directly to the ETP for treatment. The distillation column results in the removal of dissolved and entrained reservoir salts, which are extracted periodically via a salt reclaim unit and disposed of as solid waste.

3.1.2 Systems Interfacing with the TWMP

Several systems producing and/or collecting water on the LNG plant site have potential interfaces with the main collection, treatment, re-use and disposal systems covered by the TWMP. As these may at times influence the discharge quality of treated effluent being discharged through the MUBRL, they are included within this plan. These systems comprise:

- A domestic waste water collection and treatment system; and
- A demineralised water plant.

Domestic Waste Water Collection System

The domestic waste water collection system collects grey and black water from site toilet and amenity facilities (sinks, showers etc) on Site B, which houses the majority of the operational workforce. The system includes piping, pits and pumps to transport collected water to the Sewage Treatment Plant (STP), located on Site B. Treated sewage and grey water will normally be irrigated to land (therefore outside of the TWMP), however there will be periods where discharge through the MUBRL is required (e.g. during storm events or maintenance of the irrigation system). This is discussed further in Section 3.3.

Demineralised Water Plant

A demineralised water plant is provided on Site B to produce water with very low levels of salt for sensitive process needs, particularly hot water loops where high temperatures can promote corrosion if salts are present. As a byproduct, the demineralised water plant produces water with extracted contaminants (typically salts, depending on supply constituents) as a waste product.

Most of the time the demineralisation plant will be supplied from treated effluent. When this is the case, water rejected from the demineralisation plant will be directed to the final inspection tank for discharge via the MUBRL. When treated effluent is not available to supply the demineralised water plant, the plant will be temporarily supplied by a small-scale desalination plant (described in Section 3.1.3). When this is the case, water rejected from the demineralization plant may be either returned to the desalination plant and discharged with brine from this system, or discharged to the final inspection tank for discharge via the MUBRL, depending on operational requirements.

As such, normal operation of the demineralisation plant falls under the TWMP as feed to, and discharge from, the plant is directly linked to produced water and the operation of the effluent treatment plant. When the demineralisation plant is using desalinated water as feedstock, its operation is only covered by the TWMP where reject water is being directed to the MUBRL.

3.1.3 Other Production and Drainage Systems

Several further systems whereby water is produced, collected and discharged are included within the LNG plant, however these fall outside the scope of the TWMP as they do not interface with produced water at any stage. These include:

- An entirely oil free drains
- Process closed drains; and
- Small-scale desalination plant.

These systems are briefly described below, for information.

This document is protected by copyright. No part of this document may be reproduced, adapted, transmitted, or stored in any form by any process (electronic or otherwise) without the specific written consent of Woodside. All rights are reserved.

Controlled Ref No: XA0000AH0029

Revision: 0

Native file DRIMS No: 5717026

Page 16 of 57

Uncontrolled when printed. Refer to electronic version for most up to date information.

Drainage systems on Sites A and B also include an **Entirely Oil-Free (EOF) drainage system**, which comprises an open, surface water drainage system designed to collect and dispose of storm water from outside kerbed process areas on Site B and bunded areas around storage tanks on Site A and B. There is negligible risk of contamination of EOF water from the LNG plant and site operations. The EOF drainage system directs EOF water via a network of open channels, sumps and pipes to natural drainage lines around the site. In the unlikely event of a spill of a potential contaminant within an EOF area, the implementation of the site spill response procedure will ensure immediate cleanup of spills and prevent contamination of future EOF runoff.

A **process segregated drains system** is also included within the acid gas removal area containing amine compounds (aMDEA), and within the mono ethylene glycol (MEG) regeneration area. These segregated systems are considered part of the process unit, whereby drained fluids are recovered into the process and not required to be discharged to the oily water drainage systems or ETP.

A small-scale **desalination plant** is provided to supply fresh water to the site, in the absence of supply from Water Corporation. The system draws sea water from Mermaid Sound and to extract fresh water, whilst brine is discharged back into the ocean. Such small-scale systems present no environmental risk in open water systems as the brine contains no chemical contaminants and dilutes rapidly in an open water environment.

3.2 Treatment and Re-use Systems

Collected waste water treatment systems comprise an effluent treatment plant and sewage treatment plant. A description of the effluent treatment plant is provided as Section 3.2.1 and a description of the sewage treatment plant is provided as Section 3.2.4.

3.2.1 Effluent Treatment Plant

The effluent treatment plant comprises the following systems:

Controlled Discharge Facility (CDF)

All AC effluents from the plant areas are discharged through an underground header and/or open channels to the central CDF holding basins. The function of the CDF is to allow inspection and testing of effluent quality before a decision is taken to discharge to the EOF surface water system if not contaminated, or to the ETP for further treatment if contaminated. The basins are constructed from reinforced concrete and incorporate a first flush compartment and a peak overflow compartment. The CDF is designed to capture the "first flush" of rainfall (defined as 10 minutes of rainfall on the furthest area connected to the CDF) from a 1:10 year Average Return Interval (ARI) design rainfall event (equivalent to a rainfall event of 30 minutes, with an intensity of 95mm/hr). This exceeds industry practice of containing a 1-year ARI event on site. Rainfall in excess of the designed containment volume bypasses the first flush basin and is directed into the EOF drainage system.

Effluent Treatment Plant (ETP)

The ETP treats all COC, contaminated AC and produced water. The ETP provides primary, secondary and tertiary treatment of contaminated water prior to reuse or marine discharge. These treatment systems are detailed further in the sections below.

- **Oily Water Equalisation** - equalisation of the COC effluents and contaminated AC effluent occurs within the oily water equalisation tanks, which ensures homogeneity of influent flow and reduces contaminant load variations to provide a relatively consistent feed stream to downstream processes.
- **Oil Slops Tanks** - collect free hydrocarbons separated from within the ETP. Free hydrocarbons may arise from the CDF (from floating oil skimmers), oily water equalisation (from in-tank oil skimmers), oily floats from the corrugated plate interceptor (CPI) and recovered hydrocarbons from the macro porous polymer extraction (MPPE) unit. Aqueous supernatant from the oil slops tanks are decanted into the effluent treatment plant COC drainage system. Oil slops are pumped to the liquid hydrocarbon product system.

- **Corrugated Plate Interceptor (CPI)** - provides removal of free hydrocarbons and settleable sludges. Free hydrocarbons (oily floats) drain to the oil slops tanks. Silty sludges are accumulated in the CPI Sludge Pit and are transferred by vacuum tanker to the aerobic biosludge digesters, or offsite for disposal at an appropriately licensed facility.
- **Effluent Neutralisation** - pH correction is provided for downstream treatment processes.
- **Effluent Cooling** - to achieve stable operation and optimise biological treatment, the effluent will be cooled using evaporative cooling water and chilled water cooling.
- **Macro Porous Polymer Extraction (MPPE)** - any BTEX compounds present in the condensed overhead phase from the MEG regeneration process are potentially inhibitory to bacterial growth required in the water biotreatment system. The MPPE unit reduces the BTEX contaminant levels prior to subsequent biotreatment.
- **Secondary (Biological) Waste Water Treatment** - Biological treatment to degrade soluble hydrocarbons and MEG is provided by utilising membrane bioreactors (MBR). The MBR package is an activated sludge process which uses a semi-permeable membrane barrier system to separate the treated effluent from the organics-degrading micro-organisms. The activated sludge micro-organisms degrade the soluble organics to generate CO₂ and excess biomass cells. Given there are no significant nutrient sources for the biomass identified in the feed effluent stream to the ETP, the effluent is normally dosed with nutrients to sustain the biological treatment processes required to degrade soluble hydrocarbons and MEG. Optimal dosing will ensure that a minimum nutrient level is maintained to sustain biological growth within the MBR, whilst also minimising excess nutrient discharge via the MUBRL. The membranes contained in the MBR are ultrafiltration membranes capable of removing suspended solids and bacteria solids down to virus size (<2 µm). The treated aqueous effluent will contain trace levels of organics (within the approved discharge limits) and will be free of particulate solids. The membranes shall be periodically cleaned by chemical dosing systems which are typically recirculated back to the water treatment process.

Treated water from the MBR is preferentially routed to tertiary treatment prior to reuse as site service water, or where effluent supply is in excess of site service water requirement; sent to the Inspection Tanks for discharge via the MUBRL .

3.2.2 Sludge Treatment and Disposal

- **Sludge Digestion** - excess biosludge from the industrial biological treatment MBR is pumped directly to the aerobic biosludge digester. Oily water sludges can also be transferred by vacuum tanker from the CPI sludge pit into the digester. The aerobic biosludge digester has two functions; it reduces sludge mass by aerobic endogenous degradation and provides biosludge holding capacity.
- **Sludge Handling and Disposal** - the biosludges are conditioned with chemicals to enhance the dewatering characteristics of the sludge. Sludge conditioning chemicals include calcium hydroxide and polyelectrolyte and are dosed from a chemical dosing package into the agitated sludge handling tank. Excess sludge is transported via vacuum tanker offsite for disposal at an appropriately licensed facility.

3.2.3 Tertiary Waste Water Treatment (for reuse only)

The MBR aqueous effluent is passed to subsequent tertiary treatment stages, in order to obtain a treated effluent quality suitable for reuse as site service water and as feed water to the demineralised water package. The design capacity of the tertiary water treatment equipment is sized to satisfy the Pluto site service water demand only, hence tertiary water treatment will not be undertaken on water which is to be discharged into the MUBRL. It should also be noted that the membrane filtration applied in the MBR is generally considered (by industry) to provide 'tertiary' levels of wastewater treatment. The use of the word

'tertiary' in the case of the Pluto treatment system is extended to cover the treatment required to supply specific feed water quality to the LNG plant site service water demands.

The reuse treatment facility includes the following processes:

- Tertiary Membrane filtration;
- Chemical oxidation using ultra violet (UV) and ozone;
- Biological activated carbon adsorption;
- Hypochlorite disinfection.

3.2.4 Sewage Treatment Plant

The Pluto Sewage Treatment Plant (STP) is a Membrane Bio-Reactor (MBR) sewage treatment system which incorporates extended aeration, biological nitrogen removal, chemical phosphorus removal and chlorine disinfection.

The process consists of an inlet-works, a balance tank, and biological process consisting of a pre-anoxic reactor and an aeration tank or aerobic bioreactor. Two solids separation systems are available, an ultra-filtration membrane system for separation of solids from the mixed liquor, and secondary clarifier system.

The STP is designed to treat up to 150m³/day of domestic wastewater. This has been calculated based on 4,500 persons producing 33L/person/day. The system is anticipated to be downsized to support long term operation of the Pluto LNG plant, but retain the ability to treat flows up to the current design, to manage future construction and maintenance programmes.

The treated effluent is to be disposed of on site via controlled spray irrigation or used for dust suppression of construction activities where required. The required irrigation area has been determined in accordance with Water Quality Protection Note (WQPN) 22, Department of Water (DoW, 2008) and the Guidelines for Use of Recycled Water in Western Australia (WA Health,2010a). In the event of extreme wet weather events or operational restrictions preventing land irrigation, discharge will be through the MUBRL.

The STP is governed by DEC prescribed premise licence number L8299/2008/1.

3.3 Final Collection, Analysis and Disposal Systems

3.3.1 Final Collection and Analysis

Water from the effluent treatment plant surplus to site service water demand will be directed to one of two inspection tanks on Site B. The inspection tanks may also receive rejected water from the demineralisation plant (when it is using re-use water from the effluent treatment plant, and potentially when using water from desalination) and water from the sewage treatment plant (at times when irrigation is not possible but the discharge specification is being achieved).

The inspection tanks provide hold-up to allow testing of the treated effluent before water is exported from site to third party consumers as industrial grade water, or discharge into the MUBRL. Each tank has a capacity of approximately 860 m³.

The tanks are connected to the MUBRL via a buried pipeline, tied into the MUBRL near the intersection of King Bay and MOF Roads. Integral to the discharge line are a series of online constituent and quality analysers and flowrate metering.

Details relating to treated effluent discharge regime and expected contaminant concentrations are discussed further in Section 5. Details of online metering (constituents, accuracy and sample frequency) are detailed in Section 6.

The volume of effluent discharged from site is expected to be highly variable month to month and year to year. It will be heavily influenced by the frequency and intensity of rainfall, the volume of water coming in with gas from offshore and the amount of water being used (and re-used) for site service water. It is estimated that for the first LNG train of the Pluto LNG Project, the quantity of effluent will be in the order of 25-30 ML/annum, however approval has been obtained (under W4466/2008/1 and the agreement with Water Corporation) to discharge up to 146 ML/annum of water to account for high flow cases (e.g. seasons with high rainfall), increased water rates as production from the Pluto field progresses, and permitted expansion of the onshore LNG plant up to 12 million tonnes per annum LNG production.

Discharges from the final inspection tanks into the MUBRL will be completed in batches. The discharge will be intermittent and each batch will be tested (characterised) prior to release. Any batch of effluent that does not meet the monitored criteria for discharge (Section 6) will be treated in accordance with the Contingency Plan detailed in Section 8).

When discharging, the discharge flow will range between 50 m³/hr and 104 m³/hr and thus each tank will take approximately 8 to 16 hours to empty. The frequency of batch discharges will vary depending on a number of operational parameters including:

- Pluto well-field water production (i.e. during early years of operation produced water volumes are expected to be low. As the wellfield ages, produced water (PW) volumes are expected to increase);
- Status of MEG recovery operations;
- Significant rainfall in past three days;
- Service water and demineralised water demand; and
- Whether or not irrigation of treated domestic waste water is operational.

Table 3-1 summarises the operating scenarios that typify the minimum, maximum and average discharge scenarios expected over the life of the Pluto Project. This excludes treated waste water from the domestic sewage treatment plant, as irrigation is expected to occur for a high proportion of time.

Table 3-1 Main Operating Discharge Scenarios

Scenario	1 - Minimum PW flow and dry weather	2 - Minimum PW flow and wet weather	3 - High PW flow and dry weather	4 - High PW flow and wet weather
Scenario Description	All treated effluent recovered and reused as service water and demin feed.	Only a portion of treated effluent reused as service water, i.e. excess to requirements.	Slight excess of treated effluent produced beyond service water requirements.	Only a portion of treated effluent reused as service water, i.e. excess to requirements.
Effluent Stream(s) discharged to MUBRL	Reject from the demin plant.	Excess treated effluent and reject from the demin plant.	Excess treated effluent and reject from the demin plant.	Excess treated effluent and reject from the demin plant.
Discharge Volume	Average 40 m ³ generated per day (discharged intermittently).	Average 600 m ³ generated per day (discharged intermittently).	Average 170 m ³ generated per day (discharged intermittently).	Average 600 m ³ per day (discharged intermittently).
TDS of discharged effluent*	2,000 - 10,000 mg/L	< 1,000 mg/L	< 2,000 mg/L	< 1,000 mg/L

* dependent on whether water supplying the demineralisation plant is from the ETP or desalination, and thus where reject from the demineralisation plant is being directed.

3.3.2 Water Corporation Multi-User Brine Return Line

The MUBRL was constructed by Water Corporation as part of their Desalination and Seawater Supplies Project, which is an industrial and domestic water supply scheme intended to service the requirements of new industrial developments on the Burrup Peninsula. The scheme was designed to supply seawater and desalinated water to industries and also allows for the disposal of wastewater from industrial sites with the brine discharge. Water Corporation's Desalinated Water and Seawater Supplies Project, including MUBRL and discharge into King Bay, has been assessed and approved by the EPA and DEC (EPA Bulletin 1044 and Ministerial Statement No. 594) and variations under Section 45(c) of the *Environment Protection Act 1986*.

Water Corporation's environmental approval permits Water Corporation to accept treated industrial and domestic wastewater into the MUBRL from industrial process plants for which Ministerial approval and/or a Part V Licence under the *Environmental Protection Act 1986* have been issued. As at October 2010, Burrup Fertilisers Pty Ltd ammonia plant is the only industrial development that is serviced by the Water Corporation's Desalination and Seawater Supplies Project.

Woodside has entered into an agreement with Water Corporation to allow disposal of treated waste water from the inspection tanks on Site B, via a connection to the MUBRL. The agreement terms and conditions align with both Ministerial Statements 594 and 757.

The Water Corporation has provided the following information with regard to its MUBRL and ocean outfall infrastructure (pers comm. S. Wilke, CEE (2003), and Water Corporation (2010)):

- Outfall infrastructure consists of one brine break tank (2 ML capacity) located adjacent to Mermaid Marine, with valve opening for batch discharge once the tank is full (i.e. cycling approximately once per hour at current discharge rates).
- Infrastructure discharge design capacity is 208 ML/day and is estimated to be currently discharging 44ML/day of brine with Burrup Ammonia Plant being the only other current user of the infrastructure.

This document is protected by copyright. No part of this document may be reproduced, adapted, transmitted, or stored in any form by any process (electronic or otherwise) without the specific written consent of Woodside. All rights are reserved.

- The MUBRL outfall and diffuser extends approximately 800 m from the end of the Mermaid Marine groyne. The diffuser consists of 28 nozzles at 10 m spacing (total length 280 m), with a discharge angle of 30° above horizontal. To maximise mixing of the discharge with ambient seawater, the diffuser ports are directed alternately into and away from the dominant current, and discharge occurs at a fixed exit velocity of 4.5 m/s.
- Hydrodynamic and dispersion modelling has been undertaken to evaluate the diffuser design, effects of flow rate, and also assess impacts of tidal and wind conditions on effluent dispersion.
- Recent modeling undertaken for Water Corporation confirmed that, at maximum flow of 208 ML/day within a zone 120m by 400m, worst case initial dilution of effluent is 86:1. For the current daily throughput of effluent, a mixing zone of 60m by 340m achieves a worst case dilution of 75:1.

In line with the Operational Environment Management Plan for the MUBRL outfall (Water Corporation, 2010), the mixing zone for toxicants (metals) and physical and chemical stressors has been set at 86:1 dilutions, within a mixing zone of 120 m × 400 m (0.0480 km²). During more favourable conditions (incoming or outgoing tides, spring tides, high winds etc), dilution rates will be higher.

At estimated maximum average discharge rates (0.4 ML/day or 146 ML/annum), water from the Pluto LNG Project will represent in the order of:

- 2% of the total effluent stream discharged from the MUBRL at present MUBRL discharge rates;
- 0.9% annually, at present MUBRL discharge rates (approx 44 ML/day or 16,000 ML/annum); and
- 0.2% annually, at design MUBRL discharge rates (208 ML/day or 76,000 ML/annum).

At expected annual Pluto discharge volumes (30 ML/annum) and using present MUBRL discharge volumes of 16,000 ML/annum, the total quantity of waste water discharged through the MUBRL will contain an average of 0.2% Pluto waste water.

Given the very small contribution to MUBRL flows from Pluto and the presence of the 2 ML break tank prior to discharge, the resulting change in MUBRL effluent density, and thus buoyancy, will be negligible. As such, the dispersion modelling undertaken by Water Corporation remains valid and an 86:1 dilution ratio has been applied for the purposes of setting water quality parameters for Pluto treated waste water.

4. EXISTING ENVIRONMENT AT MUBRL DISCHARGE LOCATION

The following is directly extracted from the Operational Environmental Management Plan for the MUBRL (Water Corporation, 2010):

The receiving waters of King Bay have been the subject of several studies, including those of the Proponent (IRC Environment 2001; SKM 2005b). The waters of King Bay are known to be heavily modified (SKM 2005b). Chemical and ecological monitoring conducted by Woodside Energy found elevated levels of copper in oysters in the southern Dampier Port and north near the Woodside LNG plant (Woodside 1993, cited in SKM 2005a). Contrasting results however were obtained as part of the Background Quality of Coastal Marine Waters of the North West Shelf, Western Australia, a joint publication by CSIRO and DEC (Wenziker et al. 2006). According to this study, metal concentrations at the time of sampling met the environmental quality guidelines for a very high level of ecological protection (99% species protection) throughout the sampled area (Dampier Archipelago and Port Hedland), including in King Bay. However, baseline water and sediment quality monitoring undertaken by Water Corporation recorded water levels of nutrients, nickel and zinc above the ANZECC/ARMCANZ (2000) guideline trigger values for tropical marine waters (SKM 2005b).

The marine habitats in the vicinity of the seawater inlet and brine discharge points were found to be typical of habitats in the Dampier region (IRC Environment 2001). None of the marine

biota observed in the area are listed as protected, endangered, vulnerable, or threatened under the Commonwealth Environment Protection and Biodiversity Conservation Act 1999 or the Western Australian Wildlife Protection Act 1950. Burrowing worms and crustaceans were found to be the predominant fauna. Information available to date indicates that there are no extensive seagrass beds within King Bay. Coral communities are known to exist, but none are within 700 m of the brine discharge point (EPA Bulletin 1044).

The MUBRL discharges through a multi-port diffuser arrangement into King Bay, adjacent to the King Bay Industrial Estate and to the north of the Rio Tinto Parker Point iron ore loading facilities. King Bay has been a key area of industrial development since the early 1980's, in conjunction with the development of the North West Shelf Venture gas processing facilities on the Burrup Peninsula.

The area now hosts three active supply bases and two dredged navigation channels allow medium-sized vessel access to the King Bay Supply Base and Burrup Materials Facility (operated by Woodside) and the Mermaid Marine Supply Base. The brine outfall runs parallel to these dredged channels.

To the east lies an area of tidal mud flats habited by an extensive stand of mangroves. Areas around Phillip Point to the north of the MUBRL outfall and the Rio Tinto service wharf to the south west, host assemblages of sparse coral cover.

Water Corporation run a comprehensive environmental monitoring programme to quantify the composition of waste water being discharged through the MUBRL and understand what, if any, impact this is having on the local marine environment. The components of the monitoring programme are summarised in Section 6. The following is an extract from the Water Corp 2009-10 Annual Compliance Report:

All water column metals tested were below the trigger values with the exception of cadmium, copper and zinc;

Copper concentrations were higher than the ANZECC 99% species protection trigger levels at all reference sites and depths during both monitoring periods, suggesting that copper levels throughout the bay are naturally high. This is supported by previously published water quality surveys undertaken within the vicinity of the Dampier Archipelago (SKM 2009) which indicate that copper levels above the default ANZECC 99% species protection trigger levels are a wider phenomenon in the region. Therefore it is likely that the assessment of Burrup Peninsula Industrial Water Supply for compliance against the ANZECC 99% species protection trigger levels is too stringent an assessment criteria and that site specific trigger levels for copper are a more appropriate test for compliance;

Zinc concentrations were similar throughout both monitoring periods. Water column zinc concentrations exceeded the default ANZECC 99% species protection trigger levels at all sites and depths throughout the study area and both monitoring periods. These uniformly high zinc levels indicate that high zinc levels may be a wider phenomenon in waters within King Bay and independent of operation of the Burrup Industrial Water Supply marine outlet.

An effect of the marine discharge would most likely be expressed as a decreasing gradient of zinc concentration with distance from the outlet. Zinc levels were highly variable throughout the bay with higher values recorded at distances from the outlet than at the outlet. It is unlikely therefore that high levels of zinc are due to the operation of the outlet. This is supported by previously published water quality surveys undertaken within the vicinity of the Dampier Archipelago (SKM 2009) which indicate that zinc levels above the default ANZECC 99% species protection trigger levels are a wider phenomenon in the region.

Therefore it is likely that the assessment of Burrup Peninsula Industrial Water Supply for compliance against the ANZECC 99% species protection trigger levels is too stringent an assessment criteria and that site specific trigger levels for zinc are a more appropriate test for compliance;

Bioaccumulation of heavy metals in oysters deployed through the study area was evident at test and reference sites for arsenic, cadmium (outside King Bay), copper (at sites within the Bay), nickel, selenium (in bottom waters at all sites and surface waters at the boundary of the mixing zone), zinc (all sites) and mercury (all sites within the Bay) and is indicative of higher concentrations of these elements in King Bay than in oyster source waters.

This is a normal process as oysters become acclimatised to conditions within the Bay. Several metal species decreased throughout the study area: cadmium species decreased at all sites within the Bay (only increasing at the northern reference site outside of the Bay); chromium concentrations decreased at all sites throughout the study area, copper concentrations decreased at the northern reference site outside of the Bay and selenium decreased in surface waters throughout the reference sites in the Bay. Vanadium concentrations decreased in at all sites for which data was obtained. Mercury concentrations decreased in the northern reference site.

Bioaccumulation regimes were highly spatially and temporally variable throughout the study area, however no overall statistically significant difference in bioaccumulation regimes were observed between reference sites and potentially impacted sites. Therefore no effect of the desalination output on bioaccumulation was detected during 2009.

Figure 4-1 MUBRL Discharge Area and Surrounding Environment



This document is protected by copyright. No part of this document may be reproduced, adapted, transmitted, or stored in any form by any process (electronic or otherwise) without the specific written consent of Woodside. All rights are reserved.

Controlled Ref No: XA0000AH0029

Revision: 0

Native file DRIMS No: 5717026

Page 24 of 57

Uncontrolled when printed. Refer to electronic version for most up to date information.

5. DISCHARGE MANAGEMENT

5.1 Management Plan Objectives

In accordance with Ministerial Condition 7-2, the “Objective” of this Plan is to ensure that the discharge of treated wastewater is managed to achieve the following Environmental Quality Objectives (the “Objectives”), as described in the document *Pilbara Coastal Water Quality Outcomes: Environmental Values and Environmental Quality Objectives* (DoE 2006):

- Maintenance of ecosystem integrity with spatially-assigned levels of protection;
- Maintenance of aquatic life for human consumption assigned to all parts of the marine environment surrounding the ocean outlet;
- Maintenance of primary contact recreation values assigned to all parts of the marine environment surrounding the ocean outlet;
- Maintenance of secondary contact recreation values assigned to all parts of the marine environment surrounding the ocean outlet;
- Maintenance of aesthetic values assigned to all parts of the marine environment surrounding the ocean outlet;
- Maintenance of cultural and spiritual values assigned to all parts of the marine environment surrounding the ocean outlet; and
- Maintenance of industrial water supply.

Section 3 provided an overview of the technology and processes in place that are capable of delivering effluent to the inspection tanks (when required) that is fit for ocean discharge.

Section 5 describes the environmental water quality objectives have been devised and details the performance standards applied for water discharged via the MUBRL. Also provided is an estimate of the performance of the effluent treatment plant, domestic sewage treatment system and demineralised water plant based on design performance expectations and data available regarding influent constituents.

Section 6 details the ongoing monitoring programme that will be implemented, to ensure effluent discharged is within a discharge specification that meets the Objectives set out in Section 5.1, including an ongoing regime of WET testing (including the test methodology). The monitoring and discharge specification programme is adaptive over time, as understanding of system performance and effluent toxicity matures from theoretical to actual.

Section 7 outlines the protocols and schedules for reporting discharge performance against the environmental quality objectives.

Section 8 details the contingency arrangements in place to manage any waste water generated that does not meet the base specifications for ocean discharge.

5.2 Multi-User Brine Return Line Outfall Zone - Environmental Values, Environmental Quality Objectives, Levels of Ecological Protection

The *Pilbara Coastal Water Quality Consultation Outcomes: Environmental Values and Environmental Quality Objectives* were released in March 2006 (DoE 2006). This document establishes an Environmental Quality Management Framework (EQMF) and presents interim environmental goals (Environmental Values (EVs) and Environmental Quality Objectives (EQOs)) and spatially allocates these goals (Levels of Ecological Protection (LEPs)) for state waters of the Pilbara coast.

While there are no specific levels set for water quality parameters, the aim of the ratings of high, moderate and low LEPs are considered to be equivalent to the ANZECC (2000) guidelines for species protection, as follows:

Level of Ecological Protection	Species Level of Protection ANZECC (2000)
High	99%
Moderate	90%
Low	80%

A 120m by 400m initial dilution (or “mixing”) zone is currently prescribed around the MUBRL outfall. The mixing zone has been afforded a low LEP and, from the edge of the mixing zone, a high LEP has been assigned (refer to DoE (2006) Map 9, Note 4, and Water Corporation (2010)).

Woodside has therefore adopted the low LEP (80% Species Level of Protection) as the specification for discharges from the final inspection tanks. This includes contaminants that may bio-accumulate. In some instances, discharging to the low LEP criteria may not result in the achievement of the high LEP at the edge of the prescribed mixing zone. For these cases, discharge criteria for batch releases from the final inspection tanks have been back-calculated from the high LEP (using an 86:1 dilution ratio) to ensure the high LEP is met.

The discharge of wastewater through the MUBRL into King Bay is regulated through Ministerial Statement 594 as part of Water Corporation’s *Desalinated Water and Seawater Supplies Project*. As a result, Woodside also has contractual requirements with the Water Corporation to achieve specified criteria for temperature, concentration of biocide and anti-scalant at the point of discharge into the MUBRL.

It is important to note that, prior to start-up and testing of both the effluent and assessment of the impact on the receiving environment (if any), ANZECC guideline trigger values have been used as the default performance specifications. As stated in the Environment Protection and Heritage Council’s publication *National Chemical Reference Guide - Standards in the Australian Environment*:

The guideline trigger values are the concentrations (or loads) of the key performance indicators, below which there is a low risk that adverse biological effects will occur. The physical and chemical trigger values are not designed to be used as ‘magic numbers’ or threshold values at which an environmental problem is inferred if they are exceeded. Rather they are designed to be used in conjunction with professional judgment, to provide an initial assessment of the state of a water body regarding the issue in question. They are the values that trigger two possible responses:

- A. To continue monitoring – this first response, occurs if the test site value is less than the trigger value, showing that there is a ‘low risk’ that a problem exists;*
- B. Management/remedial action or further site-specific investigations – this alternative response, occurs if the trigger value is exceeded - i.e. a ‘potential risk’ exists.*

The aim with further site-specific investigations is to determine whether or not there is an actual problem. Where, after continuous monitoring, with or without site-specific investigations, indicator values at sites are assessed as 'low risk' (no potential impact), guideline trigger values may be refined.

It is therefore important to note that the current trigger values are precautionary by nature and exceedence of these trigger values does not infer "impact" but rather "a low risk of adverse effects".

As noted in Section 4, previous studies undertaken within Mermaid Sound have identified that background concentrations of copper and zinc are consistently above the 99% species protection level within ANZECC/ARMCANZ (2000), implying that a site-specific trigger level is required and the generic 99% trigger level is inappropriate for this area. Tuning of specific trigger levels for specific contaminants expected to govern toxicity is addressed within the following section.

5.2.1 Discharge Specifications

The predicted average effluent concentrations and annual loading of the chemical constituents are listed in Table 5-1. This data is based on currently available information from vendors and assuming the use of desalinated seawater as feed for the demineralisation plant when re-use water is unavailable. The data represent a conservative approach through application of the following set of assumptions to estimate constituent inputs and outputs and effect within the mixing zone.

1. All constituent concentrations refer to the Pluto ETP wastewater stream concentrations prior to entry to the MUBRL and at end of pipe as being the same value: hence, dilution with other effluents in the MUBRL has not been taken into account (although Pluto ETP waste water represents less than 2% of the instantaneous flow and usually 0.2% of the average flow through the MUBRL);
2. The effects of weathering processes and biodegradation in the mixing zone are not accounted for; and
3. Constituent concentrations have been predicted at the edge of the mixing zone following dilution with seawater, and taking into account respective background seawater concentrations.

Assumption 1 in particular shows the conservatism used in estimating the effluent outputs and quality. Taking into account the significant potential for dilution of Pluto waste water within brine being discharged by the Water Corporation desalination plant connected to the MUBRL (which will provide dilutions in the order of 50:1 to 500:1), concentrations of contaminants at the MUBRL diffuser and thus at the edge of the mixing zone from Pluto will be significantly below the figures quoted. Consideration is given to this additional dilution prior to discharge within the Contingency Plan, refer Section 8.

Assumption 2 is important also as, over time, weathering processes and biodegradation will reduce concentrations.

Production chemicals expected in the treated wastewater are also included in Table 5-1 including those production chemicals that may be used in the wastewater treatment process (for example to balance pH or enhance flocculation) but are not intended to be discharged. That is, they will be re-circulated and/or consumed in the treatment process.

Table 5-1 provide a comparison between all main constituents that might be expected within the waste water stream against the ANZECC/ARMCANZ (2000) aquatic ecosystem water quality trigger guidelines (at end of pipe and at edge of mixing zone) or predicted no-effect concentrations based on ecotoxicity information. Table 5-1 also includes the maximum expected constituent concentrations from the final inspection tanks.

Where wastewater is found to not be achieving the required protection levels at end of pipe or at the edge of the MUBRL mixing zone (after applying the 86:1 dilution ratio); one or more of the contingency management measures will be implemented (refer Section 8) to ensure discharges meet the required guideline levels or are otherwise managed appropriately.

This document is protected by copyright. No part of this document may be reproduced, adapted, transmitted, or stored in any form by any process (electronic or otherwise) without the specific written consent of Woodside. All rights are reserved.

Table 5-1 Waste Water Constituents, Sources, Expected and Maximum Concentrations, ANZECC Thresholds and Estimated Annual Loading

Constituent	Primary Source(s)	Main Control/ Removal/ Treatment Processes	Units	Predicted Average (Max) Concentration at Entry to MUBRL (and at end of pipe)	ANZECC 80% Species Protection Levels (end of pipe)	Background Concentration Dampier Archipelago (NWSJEMS 2006)	Average (Max) Concentration at Edge of Mixing Zone (86 dilutions + background concentration) ¹¹	ANZECC99% Species Protection Levels (at edge of mixing zone)	Loading (kg/yr)
Hydrocarbons (HCs)									
Total free HCs	HC Spills within AOC (Accidental Oil Contaminated) & COC (Continuously Oil Contaminated) catchment areas	Containment, oil retention baffles, oil skimming, Corrugate plate interceptors (CPI), Moving Bed Bioreactor (MPPE) & Membrane Bioreactor (MBR).	µg/L	194 (1000)	ID	Negligible	2.3 (12)	ID ¹	5.8
Total dissolved HCs, incl. BTEX	Condensed MEG Overhead from U-2100 & HC spills within AOC & COC catchment areas.	MPPE & MBR	µg/L	238 (1000)	ID	Negligible	2.7 (12)	ID ¹	7.1
Benzene			µg/L	11 (50)	1300	Negligible	0.13 (0.6)	500	0.32
Total PAHs ¹			µg/L	19 (100)	120	Negligible	0.22 (1.2)	51 ¹	0.58
Phenol			µg/L	195 (1000)	720	Negligible	2.3 (12)	270	5.8
Metals									
Total Chromium ²	Water Corporation Potable Water supply, pipeline corrosion products & produced formation waters.	Expected to be below limits. Some minimal adsorption / removal in physical and biological treatment processes. Emergency adsorption available if required.	µg/L	0.38 (1.5)	90.6	0.18	0.18 (0.2)	7.72	0.01
Chromium (VI) ²	Pipeline corrosion products & production chemicals		µg/L	0.02 (0.06)	85	ND	0.0002 (0.0007)	0.14	0.001
Lead	Water Corporation Potable Water supply & produced formation waters.		µg/L	0.5 (1.5)	12	0.01	0.016 (0.03)	2.2	0.015

This document is protected by copyright. No part of this document may be reproduced, adapted, transmitted, or stored in any form by any process (electronic or otherwise) without the specific written consent of Woodside. All rights are reserved.

Constituent	Primary Source(s)	Main Control/ Removal/ Treatment Processes	Units	Predicted Average (Max) Concentration at Entry to MUBRL (and at end of pipe)	ANZECC 80% Species Protection Levels (end of pipe)	Background Concentration Dampier Archipelago (NWSJEMS 2006)	Average (Max) Concentration at Edge of Mixing Zone (86 dilutions + background concentration) ¹¹	ANZECC99% Species Protection Levels (at edge of mixing zone)	Loading (kg/yr)
Nickel	Pipeline corrosion products and water supply Produced formation water and water supply		µg/L	0.84 (3.3)	560	ND	0.01 (0.04)	7	0.03
Zinc ¹⁰			µg/L	6.87 (36)	43	0.14	0.22 (0.56)	TBD ¹⁰	0.21
Cadmium			µg/L	0.10 (1.5)	36	0.005	0.006 (0.02)	0.7	0.003
Copper ¹⁰			µg/L	0.92 (3.6)	8	0.12	0.13 (0.16)	TBD ¹⁰	0.027
Mercury ³			µg/L	0.01 (0.03)	1.4	0.0004	0.0005 (0.0007)	0.1	0.0003
Silver			µg/L	1.1 (3)	2.6	ND	0.012 (0.03)	0.8	0.03
Others									
Temperature	Condensed MEG overhead, ambient conditions & solar radiation.	Evaporative cooling and refrigerative cooling.	°C	Compliant ⁴	-	ND	Compliant	-	Not Applicable
pH	Acids & bases used for water treatment processes (demin plant & effluent treatment plant).	Acid base neutralisation.	pH units	7.4 (6.0-9.0)	8.0 - 8.4	ND	8.1 (7.8-8.2)	8.0 - 8.4	Not Applicable
Sulphide	No significant sources.	No treatment required but any present would be stripped / oxidised within MBR.	µg/L	5 (10)	ID	ND	0.06 (0.12)	1	0.15
Process Additives									
MEG	Unit 2100 MEG regeneration distillation column condensed overheads. Production chemical spillage.	Containment, MBR	µg/L	4,225 (15,000)	ID	ND (assumed to be negligible)	49 (174)	50,000	127
aMDEA	Production chemical spillage / leaks / loss of containment.	Containment, MPPE & MBR	µg/L	185 (1,000)	ID	ND (assumed to be negligible)	2.15 (12)	200 ⁵	5.6
Liquid Polyelectrolyte	Buffering solution			Not expected in discharge					
Sodium Hypochlorite	Utilised in batch cleaning of MBR membranes with no residual chlorine expected in discharge.								

This document is protected by copyright. No part of this document may be reproduced, adapted, transmitted, or stored in any form by any process (electronic or otherwise) without the specific written consent of Woodside. All rights are reserved.

Constituent	Primary Source(s)	Main Control/ Removal/ Treatment Processes	Units	Predicted Average (Max) Concentration at Entry to MUBRL (and at end of pipe)	ANZECC 80% Species Protection Levels (end of pipe)	Background Concentration Dampier Archipelago (NWSJEMS 2006)	Average (Max) Concentration at Edge of Mixing Zone (86 dilutions + background concentration) ¹¹	ANZECC99% Species Protection Levels (at edge of mixing zone)	Loading (kg/yr)
Citric Acid	Utilised in batch cleaning of MBR membranes with no residual expected in discharge.								
Sodium Hydroxide	Utilised for pH dosing with no residual expected in discharge.								
Biocide	Very low volumes used in closed loop cooling water systems - not discharged.								
Nutrients									
Total Phosphorus	Phosphoric acid (phosphorus source for MBR)	Consumed during MBR processes	µg/L	1350 (10,000)	Annual load ⁶	ND	Not applicable	15 ⁷	45
Total Nitrogen	Urea solution (nitrogen for MBR)		µg/L	4125 (25,000)	Annual load ⁶	ND	Not applicable	100 ⁸	140
Ammonia Nitrogen (as N)	Urea solution (nitrogen for MBR)		µg/L	325 (1,000)	1700	ND	Not applicable	500	11

ND = Background data not available (background concentrations were assumed to be zero for the purpose of calculation of edge of mixing zone concentration)

ID = Insufficient Data (ANZECC/ARMCANZ 2000)

- 99% Species protection level guideline for Naphthalene (ANZECC/ARMCANZ 2000)
- 99% Species protection level guideline for Cr III (ANZECC/ARMCANZ 2000). Chromium VI is the highly toxic form of Chromium, so when total Cr is given it is usually compared to ANZECC/ARMCANZ criteria for Cr III. If and when Cr VI is measured, then it is compared directly to the Cr VI criteria
- ANZECC/ARMCANZ 80% Species Protection Level applied to end of pipe concentration is applicable as mercury has the potential to bioaccumulate
- Water Corp criteria for temperature - temperature differential at Pluto/MUBRL tie in point < 2 degrees C for 80% of the time and never exceeds 5 degrees C. NB: Temperature differential measured between Water Corporation inlet pipe (measured by Water Corp) and point of custody transfer metering point prior to Pluto tie in point to MUBRL.

- Lowest EC 50 for aMDEA with application factor (safety factor) of 100 applied
- Assessment of annual load on receiving environment (refer to Section 3.5.2)
- Tropical Australia Marine Nearshore Trigger for TP (ANZECC/ARMCANZ 2000)
- Tropical Australia Marine Nearshore Trigger for TN (ANZECC/ARMCANZ 2000)
- Hg level for 99% species protection from Water Corporation MUBRL OEMP (2010)
- 99% species protection for Zinc and Copper to be evaluated during WET testing programme, given background concentrations of these elements in Mermaid Sound exceed the default trigger levels in ANZECC/ARMCANZ 2000.
- Includes background concentration where available.

This document is protected by copyright. No part of this document may be reproduced, adapted, transmitted, or stored in any form by any process (electronic or otherwise) without the specific written consent of Woodside. All rights are reserved.

5.3 Contaminants of Concern

Table 5-1 lists the potential contaminants likely to be present in treated effluent within the final inspection tanks, including from the sewage treatment plant and demineralisation package. Although the Ministerial requirements present a very high protection threshold, design analysis and literature summarising toxicological analysis of effluent from other petroleum production facilities indicates that only a few components of the treated waste water can be expected to have a significant influence over the resulting whole effluent toxicity. Determining these components will enable the calibration of discharge quality limits during early operations (following start-up and commissioning) against whole effluent toxicity testing.

The three main factors influencing the toxicity of the treated waste water are therefore:

- The quantity of various contaminants in the ETP influent (a function of the produced water, plant drainage and operation of the plant from a cleanliness perspective);
- The toxicity of contaminants in the influent to the ETP (a function of the effect of a certain chemical constituent on marine organisms); and
- The removal effectiveness of the ETP (a function of the design and operation of the ETP).

Thus, where it is anticipated that influent concentrations of a contaminant are low (when compared to expected thresholds of toxic response), chemicals are non-toxic or have a very low toxicity or where the removal efficiency of the installed effluent treatment system is anticipated to be high, it is unlikely that those constituents will contribute significantly to the overall effluent toxicity. Therefore, when considering the likely influents to the system, design effluent parameters and toxicity of contaminants, a short-list of contaminants or parameters can be determined to allow more efficient and timely management and monitoring of discharges.

Effluent compositional and toxicological testing undertaken prior to operational Licensing will enable refinement of the chemical constituents that have a significant effect on the toxicity of the treated waste water. Whole effluent testing will enable definition of ongoing trigger thresholds for these speciated compounds for the next period of operation. An ongoing programme of whole effluent testing (refer Section 6.4) will enable regular review of both the chemical constituents governing effluent toxicity and the trigger thresholds for this.

An initial list of contaminants anticipated during the design process as potentially governing overall toxicity are detailed in Table 5-2, along with the rationale for inclusion.

Table 5-2 Chemical Constituents Expected to Govern Toxicity

Chemical or Chemical Group	Reason for Inclusion in list of contaminants or stressors governing toxicity and comments regarding influent and treatment plant design
Aromatic hydrocarbons, including BTEX and derivatives	Aromatic hydrocarbons, some derivatives of which are known from previous produced water studies to present the group of components likely to contribute to overall toxicity.
Poly-aromatic hydrocarbons	Polycyclic aromatic hydrocarbons have been documented in numerous studies on the toxicity of naturally occurring and partially refined hydrocarbons to present the group of components most likely to govern overall toxicity.
aMDEA	Water soluble process chemical, with slight to low toxicity to aquatic organisms. Storage on site may result in higher concentrations being accidentally discharged into the effluent treatment plant.
Mercury	Mercury is bio-accumulating in organisms and can be present in hydrocarbon streams. Whilst not immediately toxic at very low levels, potential for accumulation in the food chain makes this a constituent requiring monitoring. <i>It is noted that mercury removal beds are provided at the plant which is highly effective at removing mercury to very low levels.</i>

Due to produced formation water being stripped of salt prior to the water being sent to the effluent treatment plant and potable water now expected to be generated through seawater desalination, metals that can not enter a vapour phase at low to moderate temperatures are not expected in any significant quantity in treated

This document is protected by copyright. No part of this document may be reproduced, adapted, transmitted, or stored in any form by any process (electronic or otherwise) without the specific written consent of Woodside. All rights are reserved.

waste water. Commissioning testing will confirm this hypothesis, results of which will be provided to the DEC at the completion of commissioning through the commissioning compliance reporting and licence application process (refer Section 7).

Following completion of the WET testing and ratification of the list of chemical constituents of concern from a toxicity (and bioaccumulation potential, where applicable) perspective, a discharge concentration that achieves the ANZECC 99% species protection requirements at the edge of the mixing zone can be set and an understanding of the permissible range of constituent concentrations determined, to enable monitoring by the operations team and management (and the potential implementation of contingency arrangements) to ensure the defined discharge criteria are achieved.

6. MONITORING PROGRAM

Monitoring of the effluent quality and quantity of water discharged from the final inspection tanks is required to ensure discharges to the MUBRL are within specification, provide information to allow for continual improvement in effluent discharge quality and allow adaptive management if the specification for direct discharge has not been achieved. Testing is largely conducted on water in the final inspection tanks as this, rather than treated water from the effluent treatment plant, is what will be released to the MUBRL and some contaminants of interest may be generated by other systems tied to the final inspection tanks (e.g. likelihood of nutrient load from the sewage treatment plant, when output from the plant is diverted to the final inspection tanks).

The effluent treatment plant monitoring programme has been split into two phases, recognising the different operational modes of the effluent treatment plant, objectives of each phase and complementary approvals processes. The phases comprise the start-up and commissioning phase; and ongoing operations phase.

The start-up and commissioning phase commences on introduction of potable or sea water to the effluent treatment plant for start-up purposes (i.e. other than for hydrotesting) and the phase will be deemed complete when a License under Part V of the *Environment Protection Act 1986 (WA)* is issued for the plant, anticipated to be approximately nine months following introduction of process waste water. The monitoring programme for this phase, including whole effluent toxicity testing, is summarised in Section 6.1 and 6.4.

The ongoing operations phase commences immediately upon Licensing once plant operation and effluent toxicity has been investigated and continues for the life of the Pluto LNG Project. The monitoring programme for this phase is detailed in Section 6.2 and 6.4.

Marine monitoring around the outfall is conducted for the wider MUBRL user group by the Water Corporation and fulfils part of Woodside's monitoring requirements and obligations. This is outlined in Section 6.3.

6.1 Monitoring during Start-up and Commissioning

Monitoring during start-up and commissioning of the effluent treatment plant is intended to aid in the commissioning of the plant in an efficient and timely manner, identify any weaknesses in the treatment system, equipment or operational procedures, understand the actual (rather than theoretical) toxicity of waste water likely to be produced throughout stable operations and ultimately ensure the environmental and social values of the discharge location are protected over the operational life of the facility. Monitoring during this phase is designed to provide an interim means for evaluating whether treated waste water is suitable for discharge, prior to whole effluent toxicity testing being conducted (towards the end of the commissioning phase).

The programme of monitoring during start-up and commissioning is detailed in the *Pluto LNG Project Effluent Treatment Plant Commissioning Plan, Woodside Doc. XA0000AR0875*, approved by DEC under Works Approval W4466/2008/1.

During this phase, testing for groups of contaminants and environmental stressors will be undertaken to indicate overall compliance or prompt a management response (i.e. implement the commissioning contingency plan). Contaminant groups and environmental stressors to be monitored include:

- Total organic compounds (TOC), which indicate the presence of MEG, free and dissolved hydrocarbons, aromatic and poly-aromatic hydrocarbons and phenol;
- Temperature and salinity, to ensure compliance with Water Corporation discharge limits, and
- pH, free chlorine and nutrients (Nitrogen and Phosphorous), which may indicate incorrect dosing of buffering, supplemental food and/or disinfectant.

Contingency plans in the format of decision trees detail how in-specification and out-of-specification water will be managed such that the ecological and social values of the receiving environment are protected during

This document is protected by copyright. No part of this document may be reproduced, adapted, transmitted, or stored in any form by any process (electronic or otherwise) without the specific written consent of Woodside. All rights are reserved.

Controlled Ref No: XA0000AH0029

Revision: 0

Native file DRIMS No: 5717026

Page 33 of 57

Uncontrolled when printed. Refer to electronic version for most up to date information.

the commissioning period.

A programme of internal and external quality assurance testing is also specified within the plan to ensure calibration of online and in-field tests against NATA-accredited analysis standards.

6.2 Monitoring during Ongoing Operations

Regular water quality monitoring, analysing for contaminants of interest and chemicals or stressors required for compliance with Water Corporation requirements, will be undertaken on the effluent to be discharged utilising the installed analysers and field laboratory prior to release from the final inspection tank(s) into the MUBRL. This batch testing programme is supported by a complementary internal and third party laboratory sampling regime. Internal laboratory assessment will be conducted quarterly, to ratify the online sampling programme, confirm the effluent is still aligned to the compositional analysis of waste water subject to whole effluent testing and test for parameters unable to be practicably tested online. An external NATA accredited laboratory will conduct a full suite of analysis on treated waste water annually, to provide independent verification of the internal field and laboratory sampling results and provide results for any exotic species unable to be practicably assessed using the online, field or internal laboratory equipment.

Table 6-1 outlines the various components of routine compositional monitoring programme that will be implemented during the operational phase, to ensure the plant is operating as intended, waste water is treated to a specification suitable for discharge and discharge criteria specified for the MUBRL are achieved.

Table 6-1 Routine Operational Monitoring Programme

Analytes	Detection Limit/ Range	Turn-around Time	Sampling Frequency	Indicator / Purpose of Monitoring
Online analysers (final inspection tank outlet)				
pH	0-14	Complete suite available after approximately 10 minutes from sampling	Analysis for each batch discharged	Indicates general treatment process 'health'
Total Organic Carbon (TOC)	<2 - 200 ppm			Used to screen for potential MEG, hydrocarbon, aromatic and PAH contamination, components of which are expected to govern whole effluent toxicity
Total Dissolved Salts (TDS)	<200 - 20 000 uS/cm			Tests conductivity / salinity. Required to demonstrate compliance with MUBRL discharge requirements and indicates general treatment process 'health'
Total Suspended Solids (TSS)	>2 NTU			Tests for total suspended solids / indicates general treatment process 'health'
Temperature	0 – 45°C			Confirms discharge water temperature, for comparison against background. Required to demonstrate compliance with MUBRL discharge requirements
Free Chlorine (Cl)	<0.5 - 5 ppmv			Tests for the presence of residual chlorine and oxidising biocide, to demonstrate compliance with MUBRL discharge requirements
Flow rate and volume	<0.2 - 200 m ³ /hr		All discharges recorded	Flow rate and volume, allowing calculation of total loading and fulfil requirements of the MUBRL discharge agreement
Field Laboratory				
Total Nitrogen	<0.1 mg/L	Available within approximately 5 hours	Sample analysed for each batch, for first year of	Indicates general treatment process 'health' and allows confirmation of total annual loading
Total Phosphorous	<0.01 mg/L			Used to screen for potential
Total Free and Dissolved	<5 mg/L			

This document is protected by copyright. No part of this document may be reproduced, adapted, transmitted, or stored in any form by any process (electronic or otherwise) without the specific written consent of Woodside. All rights are reserved.

Hydrocarbons (HORIBA)			operations, then quarterly	hydrocarbon, aromatic and PAH contamination, components of which are expected to govern whole effluent toxicity
MEG	<10 – 100 mg/L			Indicates general treatment process 'health'
Pluto Laboratory Facilities				
pH	0-14	5 days laboratory analysis	Quarterly, to verify online analyser results and confirm that produced water composition is broadly consistent with the composition subjected to whole effluent toxicity testing.	Indicates general treatment process 'health'
Total Suspended Solids (TSS)	<2 mg/L			Tests for total suspended solids / indicates general treatment process 'health'
Total Dissolved Salts TDS / Conductivity	<2.5mg/l and <5 uS/cm			Tests conductivity / salinity, MUBRL discharge compliance and indicates general treatment process 'health'
Total Organic Carbon	<2 mg/L			Used to screen for potential MEG, hydrocarbon, aromatic and PAH contamination, components of which are expected to govern whole effluent toxicity
Total Free and Dissolved Hydrocarbons (HORIBA)	<5 mg/L			Used to screen for potential hydrocarbon, aromatic and PAH contamination, components of which are expected to govern whole effluent toxicity
MEG Concentration	<10 mg/L			Indicates general treatment process 'health'
aMDEA	<15 mg/L			Used to screen for potential aMDEA concentrations in treated waste water, which may be a toxicant governing whole effluent toxicity if an accidental release from site increases influent levels to the treatment plant
Sulphide	<0.1 mg/L			Indicates general treatment process 'health'
Total Phosphorus (as P)	<0.01 mg/L			Indicates general treatment process 'health' and allows confirmation of total annual loading
Total Nitrogen (as N)	<1 mg/L			
Ammonia Nitrogen (as N)	<1 mg/L			
Total Kjeldahl-N (as N)	<3 mg/L			
Chromium (total)	<50 µg/L			
Lead	<50 µg/L			
Nickel	<20 µg/L			
Zinc	<50 µg/L			
Cadmium	<10 µg/L			
Copper	<30 µg/L			
Silver	<100 µg/L	Enables confirmation that metals remain at levels below which they would be anticipated to significantly influence whole effluent toxicity, or trigger response if a significant change in levels is observed that is also significant when compared to ANZECC trigger levels		
Mercury	<1 µg/L		Used to confirm bioaccumulation potential is minimised and Hg ANZECC 99% / 80% discharge limits met	
Independent/Third Party Laboratory (NATA Accredited)				
All parameters listed in Table 5-1 (excluding temperature).	Subject to lab and test method	Approximately 1 month	Annually, full analysis suite. Conducted at the same time as the annual WET test.	NATA Accredited third party full-suite compositional analysis to provide the reference compositional baseline for the following 12-month discharge criteria and provide independent validation of on-site and laboratory testing.

If a whole effluent toxicity test prompts a change to the list of contaminants (expected to) govern effluent toxicity (Table 5-2), Table 6-1 will be amended accordingly to include tests for additional chemicals/stressors

This document is protected by copyright. No part of this document may be reproduced, adapted, transmitted, or stored in any form by any process (electronic or otherwise) without the specific written consent of Woodside. All rights are reserved.

as far as is practicable, or conversely to remove testing for chemicals/stressors considered no longer of concern. The operational testing regime is anticipated to be able to be focussed once operational experience has been obtained and effluent toxicity evaluated. Changes to the operational testing regime identified in Table 6-1 will be managed as part of the annual Licensing process with the Department of Environment and Conservation.

6.3 Marine Monitoring

The Water Corporation undertake an extensive operational water quality monitoring programme of waste water discharging from the MUBRL, on behalf of itself and the Burrup Users Group (comprising the users of the MUBRL, which includes Woodside). At the time of preparing this plan, the programme consists of both programmes to analyse the quality and physical parameters of the waste water being discharged through the MUBRL as well as investigations of the receiving environment to determine whether the discharge is having a measurable and/or significant impact on the receiving environment.

Key aspects of the Water Corporation monitoring programme currently include:

- Waste water compositional analysis (usually conducted quarterly in January, April, July and October) analysing for metals (Cobalt, Cadmium, Chromium (III) and (VI), Copper, Iron, Mercury (inorganic), Nickel, Silver, Vanadium, Lead and Zinc), nutrients (Ammonia, Total Nitrogen and Total Phosphorous), salts (Bicarbonate, Bromide, Calcium, Carbonate and Potassium), particulates (total dissolved solids, suspended solids, total organic carbon and turbidity) and physical chemistry (conductivity, dissolved oxygen and temperature);
- Whole effluent toxicity testing (72 hour sea urchin larval development test (annually, in summer) and full suite test if 72 hour test triggers full testing);
- Receiving water quality monitoring within the discharge area (annually), analysing water temperature, salinity, CTD and dissolved oxygen;
- Sediment quality monitoring within the discharge area (every two years), analysing for grain size distribution and metals (aluminium, arsenic, cadmium, cobalt, copper, lead, mercury, nickel, selenium, silver and zinc); and
- Bio-monitoring within the discharge area (three-yearly, unless varied) using sentinel oysters to detect assimilation of heavy metals and/or metalloids.

The monitoring program is coordinated by Water Corporation on behalf of the members of Burrup Users Group (BUG), of which Woodside is a member. In addition to the operational ocean monitoring program, the Water Corporation continuously monitors flow rate, temperature, pH, conductivity, REDOX potential, ammonia and turbidity at the outfall break tank, as well as the temperature of the receiving waters. Concentrations of oxidising biocide and antiscalent in the MUBRL effluent discharge are also measured to ensure compliance with the Water Corporation's discharge criteria concentrations of 0.1 mg/L and 2 mg/L respectively.

All reporting of results from this programme externally will be managed by the Water Corporation on behalf of the BUG members, via existing compliance reporting processes defined by Ministerial Statement 594.

6.4 Whole Effluent Testing

6.4.1 Requirements

In accordance with Ministerial 757, Condition 7-2(4) supported by the requirements of Schedule 5, Whole Effluent Toxicity (WET) testing of waste water consistent with the protocols and procedures recommended in ANZECC/ARMCANZ (2000) will be completed on waste water from the final inspection tanks. The aims of the testing are to:

- Determine the toxicity of the wastewater; and
- Evaluate the potential risks to the marine environment associated with the marine discharge, including

This document is protected by copyright. No part of this document may be reproduced, adapted, transmitted, or stored in any form by any process (electronic or otherwise) without the specific written consent of Woodside. All rights are reserved.

specifying the elements of the treated waste water likely to govern toxicity and determining the number of dilutions required to meet a high level of ecological protection (to inform updates to Table 5-2, Table 6-1 and routine discharge management).

The initial and ongoing WET testing programme, combined with the companion compositional analysis will provide empirical data to support an annual review of the list of contaminants/stressors and their corresponding discharge limits detailed in Table 5-1, Table 5-2 and Appendix C and thus provide an iterative management approach throughout the life of the treatment and discharge facilities.

6.4.2 Methodology

WET testing will be undertaken in accordance with the requirements of ANZECC/ARMCANZ (2000) on treated water from the final inspection tanks. ANZECC/ARMCANZ (2000) requires a suite of chronic tests using (at least) five different species from four different taxonomic groups, including at least one fish and shellfish test, to reliably determine effluent toxicity.

The tests will generate a suite of statistics defining whole effluent toxicity, which will enable the discharge criteria to be validated or amended if required based on real toxicity results, as well as provide additional information to assess contingency plans.

Testing will be carried out by independent specialists in WET testing according to ANZECC/ARMCANZ (2000), in accordance with the following:

- Samples of effluent will be collected from the final inspection tanks and transported to the laboratory conducting the WET test in line with standard laboratory procedures and controls.
- Each sample will have its salinity assessed and adjusted to that of normal seawater (33,000 to 36,000 ppm) using either artificial sea salts or deionised water as appropriate.
- Each sample will be diluted in a geometric series aligned to the MUBRL diffuser performance (100%, 50%, 25%, 6.25%, 3.125% and 1.16%, with 1.16% being equivalent to the worst case initial dilution of the MUBRL) using seawater.
- The WET tests will be conducted for the seven species listed in Table 6-2. Each test will typically consist of at least eight treatments – a control (seawater with no toxicants), two salinity controls (sea water at two different salinities that cover the range of salinities that will occur in non-control treatments) and five increasing concentrations of a sample.
- The WET tests will be conducted using standard operating procedures based on published methodologies.

The test species and test methods selected are as per the MUBRL OEMP, to ensure consistent information is generated within the one outfall system. If changes to the MUBRL OEMP WET test suite are made, the tests/species listed below will be updated to reflect the MUBRL WET test methodology. Species and test methodologies current at the time of preparation of this plan are presented in Table 6-2 for information only.

Table 6-2 WET Test Summary

Species	Test
Doughboy scallop	48 hr larval development test
Sea Urchin (<i>Heliocidaris tuberculata</i>)	Fertilisation test
Mussel	Larval development test
Copepod	21-28 day reproduction test

This document is protected by copyright. No part of this document may be reproduced, adapted, transmitted, or stored in any form by any process (electronic or otherwise) without the specific written consent of Woodside. All rights are reserved.

Macroalga (Ecklonia sp.)	48-hour germination test
Algae (<i>Nitzschia closterium</i> and <i>Isochrysis</i> sp.)	Growth inhibition test
Fish (species dependent on seasonal availability)	7-day larval growth test

6.4.3 Test Timing

The initial WET test shall be conducted within three months following commissioning and stabilisation of the ETP and is covered by the requirements of the *Pluto LNG Project Effluent Treatment Plant Commissioning Plan* (approved by DEC). The completion of the “stabilisation” phase will be determined through analysis of results from water quality monitoring undertaken during the commissioning period (refer Section 6.1) and be defined as when the ETP exhibits satisfactorily predictable responses to changes in influent flowrates or characteristics. Given the dynamic nature of in particular the biological aspects of the treatment process, this will be an objective decision based on operator experience, including consideration of monitored results.

Once stable operation has been achieved, analysis of routine water quality monitoring data will be correlated to the operation of the plant over a two month period. In particular, the proportion of different feed streams; produced water, rainwater (if rain falls during the stabilisation period); and influent from other sources (demineralisation and sewage treatment plant, if occurring) will be correlated to effluent quality data to determine what represents the “worst case” wastewater composition produced through stable operation of the plant. “Worst case” will also, by necessity, be a subjective call and will be based, as far as practicable, on the concentrations of contaminants expected to govern toxicity, with consideration also given to other contaminants if these prove much higher than design and/or exceed the ANZECC trigger levels.

The WET test will be conducted within the following month, at a time most likely to represent the “worst case” condition predicted by the previous two months analysis, noting that some factors that contribute to the “worst-case” may not be present (e.g. in the event that sewage irrigation is in operation or there is no rainfall, if these turn out to be contributing factors to the “worst case”), or additional factors may be present that were not present within the preceding two months.

Subsequent WET tests will be conducted either within 1 month following the anniversary of the initial WET test, annually, or immediately (within 2 months) following any significant, sustained increase in the levels of contaminants of concern within the treated wastewater.

The results of the ongoing WET testing programme will be used to inform both initial and ongoing Licensing. An illustration of how WET testing, performance review and Licensing processes fits within the start-up and commissioning phase and ongoing operations is provided as Figure 6-1.

Figure 6-1 WET Testing, Performance Review and Licensing Programme Flow

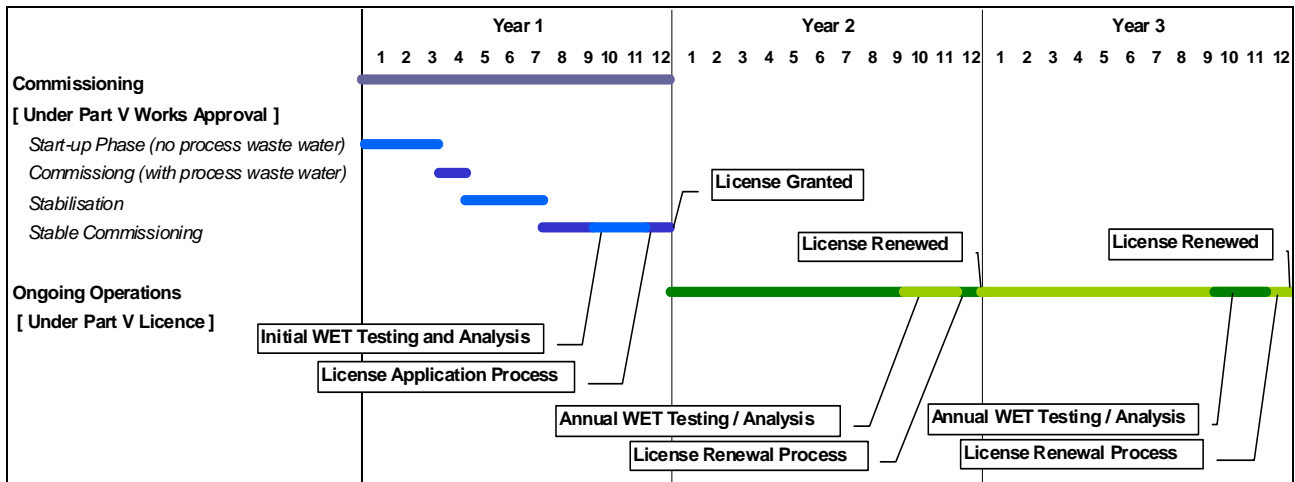

6.4.4 WET Test Quality Assurance

Samples will be collected, stored and transported according to the relevant parts of Australian Standard AS/NZS 5667.1:1998 and all tests will be conducted by laboratories with NATA-accredited methods, as far as practicable.

7. PERFORMANCE REPORTING

7.1 Routine Reporting

The performance of the effluent treatment plant and associated systems will be collated routinely. All performance reports will be provided to the regional office of DEC (Pilbara) as DEC will also be regulating compliance with the ETP Works Approval W4466/2008/1 and future Part V Operating License.

Commissioning Compliance Report

A compliance report will be prepared at the completion of the start-up and commissioning period (following the inaugural WET test results becoming available) as part of an application for a Part V License under the *Environment Protection Act 1986*.

The compliance report will include:

- A summary of the monitoring results over the last three months of (stable) operation;
- The results of the commissioning WET test and full suite compositional analysis;
- Justification as to the appropriateness of the WET test timing (against the criteria within Section 6.4.3);
- Selection of the constituents expected to govern effluent toxicity, along with associated discharge criteria for the following 12 months (or until a significant, sustained change on chemical composition is observed in the treated waste water) that permits free discharge from site (template included in Appendix C of this plan) with justification as to the appropriateness of the constituents and discharge standards selected based on the WET testing and compositional analysis results.

Annual Licence Report

Following completion of the commissioning phase and submission of the commissioning compliance report, annual operating performance data will be provided to the Manager, Pilbara Region, Department of Environment and Conservation within an annual licence report.

The annual licence report will include a summary of:

- The volumes of waste water discharged from the final inspection tank to the MUBRL;
- The chemical constituents governing toxicity and their levels within the effluent discharged;
- The use of alternative management measures (contingencies) detailed in Section 8 (where applicable);
- The results of the annual WET test and full suite compositional analysis;
- An assessment against the Environmental Quality Objectives as to the appropriateness of the discharge criteria either re-confirming that the current criteria are appropriate for a further 12 months (or until a significant, sustained change on chemical composition is observed in the treated waste water), or providing a table of revised criteria, with justification based on the WET testing and compositional analysis results.

7.2 Start-up and Commissioning Phase

Reporting of performance during the start-up and commissioning phase (notionally six to twelve months from first commissioning activities) will be in accordance with the Pluto LNG Project Effluent Treatment Plant Commissioning Plan, Woodside Doc. XA0000AR0875.

7.3 Exception Reporting

Where effluent is discharged to ocean from the MUBRL not in accordance with either the approved discharge specifications or the Contingency Waste Water Management Plan detailed in Section 8, the Department of Environment and Conservation will be notified as follows:

This document is protected by copyright. No part of this document may be reproduced, adapted, transmitted, or stored in any form by any process (electronic or otherwise) without the specific written consent of Woodside. All rights are reserved.

Initial Notification

The Manager, Pilbara Region, Department of Environment and Conservation will be notified by the close of business on the next business day following detection and verification of the event.

Full Notification

A report describing the event will be provided to the Manager, Pilbara Region, Department of Environment and Conservation within 10 business days following detection and verification of the event.

This will include:

- The time and date of the event;
- Details of the event (what was discharged, how much etc);
- Details of what occurred that caused the event;
- An analysis of the risk to the environment and Objectives from the event;
- Any measures taken to reduce the discharge or protect the Objectives; and
- Any measures to be taken to prevent reoccurrence.

7.4 Other Reporting

The agreement in place with the Water Corporation for use of the MUBRL specifies water quality and quantity reporting requirements that must be adhered to by Woodside and provided to Water Corporation as part of its accountabilities in managing the MUBRL outfall. These fall outside the scope of this plan.

8. CONTINGENCY WASTEWATER MANAGEMENT PLAN

The final inspection tanks provide hold-up and the opportunity to test the treated effluent before exporting off-site to third party consumers as “industrial” grade water and/or discharging into the MUBRL. The tanks also provide a limited storage capacity in the event that testing determines that the effluent does not meet the approved discharge specification for whatever reason.

Water within the final inspection tanks could be outside the discharge specification for a range of reasons including, but not limited to: failure of an individual element of the treatment system (which may affect the resultant concentrations of one or several waste water constituents), failure of the full system (e.g. due to loss of power, operator error or death of the activated sludge bacteria), unanticipated constituent inflows or treatment system performance. The design of the effluent treatment plant and upstream and downstream equipment has minimised the potential for failure of a system (by providing redundancy and limiting influent components of concern as far as practical e.g. salt removal, localised bunding of chemical storages and pumping system) and minimised the impact of failure (through redundancy, system monitoring, alarms etc) to as low as practicable. However, it is prudent to have in place a range of contingency measures that can be implemented to manage off-specification water to ensure ocean discharge objectives are maintained as far as is reasonably practicable, whilst ensuring the continued operation of the Pluto LNG trains.

Whenever waste water within the final inspection tanks is observed to be outside of the discharge specification the operations team will consider what the most appropriate contingency arrangement is and then implement that contingency. Section 8.1 provides details of the principal options available to manage off-specification water. Section 8.2 provides a basic decision methodology for determining the appropriate course of action to take.

In the unlikely event that the outfall is unable to achieve the Objectives, the MUBRL operator (Water Corporation) has committed to investigating solutions to achieve the Objectives which, depending on the risk posed, may require modification of the marine outfall. The management actions proposed by Water Corporation are reproduced in Section 8.3.

8.1 Contingency Management Options

The following primary options are available to the operations team to manage waste water within the final inspection tanks that does not meet the discharge specification. It is noted that each option will not be viable for each and every scenario for which a contingency plan may need to be implemented.

A high level basis for enacting each contingency case is provided. Section 8.2 provides a basic decision framework for determining the most appropriate course of action to take and specifics regarding the implementation of that contingency option.

Options include:

- Recycle effluent through the MBR – refer 8.1.1
- Discharge to MUBRL following assessment of MUBRL operations –Section 8.1.2
- Discharge to MUBRL following risk assessment - Section 8.1.3
- Emergency absorption - Section 8.1.4
- Onsite irrigation - Section 8.1.5
- Offsite disposal to ToxFree or alternative treatment facility - Section 8.1.6
- Diversion of non-process waste water – Section 8.1.7
- Temporary storage – Section 8.1.8
- Emergency discharge – Section 8.1.9

An explanation of each option is included below, stating what the option entails, when it is (and is not) effective and what happens to the effluent once the option is enacted.

8.1.1 MBR Recycle

This involves recycling water from the MBR permeate tank, or final inspection tanks back to the front end of the MBR.

This strategy is appropriate when:

- The MBR is running below design influent capacity and the final inspection tanks have sufficient ullage to allow for recirculation;
- Levels of contaminants are between MBR design maximum levels and discharge specifications; and
- The individual contaminants that exceed the discharge specifications are removed by the MBR.

Recycling the contents of the final inspection tanks back through the ETP may impact the capability for water reuse as the demineralisation package is unable to accept and treat water with a TDS concentration greater than 1178 mg/L. Thus, recycling from the final inspection tanks may decrease re-use of waste water.

Recycled effluent is returned to one of the final inspection tanks for further analysis and does not result in discharge outside the discharge specification.

8.1.2 Discharge to MUBRL Following Assessment of MUBRL Operations

As noted in Section 5.2.1, discharge specifications are calculated using a dilution ratio of 86:1, as was calculated by Water Corporation for operation of the brine return line in normal operation. This means that significant additional dilution of treated waste water from the Pluto LNG Project will inherently be achieved between the final inspection tank release point and discharge at the MUBRL ocean diffuser. In all cases where the brine line is disposing of brine, pre-discharge dilution of treated waste water from the Pluto final inspection tanks will be significantly higher than that achieved within the outfall mixing zone.

An ongoing programme of analysis of brine conducted by the Water Corporation provides the following estimate of “average” contaminant levels as summarised from data presented in the Water Corporation MUBRL 2009/2010 Annual Compliance Report (from Appendix 4):

Table 8-1 MUBRL Discharge Quality for 2009/2010]

Parameter	Average Level
Total Petroleum Hydrocarbons (TPH)	Not monitored – assume nil
Aromatic and Poly-Aromatic Hydrocarbons	Not monitored – assume nil
Mono-Ethylene Glycol (MEG)	Not monitored – assume nil as not used within other BUG facilities
Activated Methyl-Diethanol Amine (aMDEA)	Not monitored – assume nil as not used within other BUG facilities
Mercury	Monitored in receiving environment only.
Temperature	7% exceedence of 2°C (2009-20 reporting period)

This document is protected by copyright. No part of this document may be reproduced, adapted, transmitted, or stored in any form by any process (electronic or otherwise) without the specific written consent of Woodside. All rights are reserved.

Where constituents of the treated waste water from the Pluto facilities are not present or are present in low concentrations in the larger brine stream (e.g. hydrocarbons and aMDEA, which are non-existent in the brine to date), the brine will provide additional dilution prior to discharge. Where brine contains quantities of constituents, the full value of dilution can not be claimed, but can be calculated through a simple mass balance, as follows:

$$\text{Total Concentration of Species [X] in discharged effluent} = \frac{(X_{cw} \times F_{yw}) + (X_{cp} \times F_p)}{(F_{yw} + F_p)}$$

Where: X_{cw} = the concentration of the constituent in the Water Corporation brine reject stream
 F_{yw} = the total flow of water from Water Corporation over a 12 hr period during the scenario
 X_{cp} = the concentration of the constituent in the treated water from the final inspection tanks
 F_p = the volume of the final inspection tank to be discharged

A revised set of discharge specifications can be calculated for periods where it can be confirmed that the MUBRL is discharging brine (in line with the operational mode of the MUBRL and break tanks, detailed in Section 3.3.2) and based on the average pump out rate for emptying 0.86 ML from one of the final inspection tanks (12 hours) detailed in Section 3.3.1. These are calculated below for three “typical” MUBRL operational scenarios likely to occur throughout the life of the Pluto LNG Project, based on the annual average discharge water quality provided by Water Corporation (Table 8-1).

- Scenario 1 – MUBRL operating at current flow (44 ML/day) resulting in dilution of 0.86 ML of treated water from the final inspection tanks into 22 ML of brine;
- Scenario 2 – MUBRL operating at half capacity (120 ML/day) resulting in dilution of 0.86 ML of treated water from the final inspection tanks into 60 ML of brine; and
- Scenario 3 - MUBRL operating at full capacity (208 ML/day) resulting in dilution of 0.86 ML of treated water from the final inspection tanks into 104ML of brine.

Further scenarios can be generated simply, where inflows to the MUBRL change significantly but not in alignment with the scenarios calculated below.

Table 8-2 Discharge Limits Incorporating Brine Dilution

Chemical or Chemical Group	Discharge Limit Concentration	Unit	Final Inspection Tank Discharge Spec: Scenario 1	Final Inspection Tank Discharge Spec: Scenario 2	Final Inspection Tank Discharge Spec: Scenario 3
Total Petroleum Hydrocarbons (TPH), including Aromatic and Poly-Aromatic Hydrocarbons	5	mg/L	125 mg/L	250 mg/L	600 mg/L
Activated Methyl-Diethanol Amine (aMDEA)	17	mg/L	430 mg/L	1,186 mg/L	483 mg/L
Mercury	HOLD ¹	mg/L	¹ To be confirmed, following confirmation of concentration of Hg in MUBRL effluent and background concentrations.		
Temperature	±5	°C	Subject to operating temperature of MUBRL discharge and receiving seawater temperature.		
	±2	°C			

This option is appropriate at all times where confirmation of the operating scenario of the MUBRL has been confirmed by Water Corporation. Discharges to ocean comply fully with the Objectives prescribed, taken from an actual “end-of-pipe” perspective and noting that the discharge criteria are established based on ANZECC principles of the limits being a point at which there is a “low risk of negative effects”, not a point at which negative effects occur. At present insufficient data was available to evaluate whether mercury

This document is protected by copyright. No part of this document may be reproduced, adapted, transmitted, or stored in any form by any process (electronic or otherwise) without the specific written consent of Woodside. All rights are reserved.

concentrations in the MUBRL effluent and receiving environment are such that dilution in the MUBRL brine may be utilised. Further assessment is required on this aspect prior to use as a contingency.

If confirmation from Water Corporation can not be obtained, or the specification of water within the final inspection tanks does not meet the corresponding specification from Table 8-2, this contingency option can not be used.

Influent to the MUBRL from all users is routinely monitored under the Water Corporation Operations Environmental Management Plan (OEMP) for the MUBRL and agreements with users ties them to compliance with the overarching compliance parameters contained within the OEMP and Ministerial Statement 594. Thus regular verification of the discharge parameters within Table 8-1 can be conducted. Where parameters within Table 8-1 change, the discharge limits within Table 8-2 will be updated to ensure the Objectives continue to be achieved.

8.1.3 Discharge to MUBRL following Risk Assessment

Discharge criteria based on WET testing will provide a good operational basis for discharge management, however it must be accepted that discharge quality will vary and the relative concentrations of various constituents will not be constant. As such, it is reasonable to envisage periods where some elements of the treated waste water exceed the specified thresholds, whilst other constituent concentrations may remain well below the prescribed threshold. As ANZECC/ARMCANZ (2000) methodologies will result in conservative species protection guidance levels for marine discharges that present a “low risk” of impact, it is appropriate to enable case-by-case analysis of a waste water sample and the concentration of certain contaminants within that water and assess whether discharge of that water would still achieve the Objectives. Conservatisms within the 12-month discharge criteria approach include:

- Conservatisms in brine dilution during discharge;
- Conservatisms in the dilution achieved within the mixing zone (outside “worst case” mixing of 86:1); and
- Conservatisms due to “batch” benefits of discharges (ranging from 30hrs to 24 days between batches).

This is outlined in further detail in Section 5.2. Where effluent within a final inspection tank does not comply with all aspects of the discharge criteria and brine dilution (refer Section 8.1.2) can not achieve compliance with the Objectives for whatever reason, a desktop risk assessment that considers all aspects of the effluent, the likely fate of any constituent within the marine environment, the frequency of discharges occurring and any other relevant factors, may indicate that discharge represents a low to negligible risk of not achieving the Objectives. A template for the risk assessment is provided as Appendix B. The risk assessment will be presented to the Manager, Pilbara Region, Department of Environment and Conservation for approval. Approval will be obtained prior to the discharge occurring. Records of risk assessments undertaken and approved risk assessments will be kept.

It is appropriate to consider completion of a risk assessment where recycle through the MBR (refer Section 8.1.1) or discharge through the MUBRL taking account of dilution with brine (refer Section 8.1.2) can not achieve the discharge specification but where assessment can demonstrate that risk is low or negligible and sufficient time is available to complete an appropriate level of risk assessment.

Where the risk is unable to be assessed as low to negligible, or the risk assessment has yet to be approved by DEC, this contingency option can not be used. It is unlikely that this option can be used where the final inspection tanks experiencing high inflows, due to the inherent time required to analyse water quality, assess the risks and obtain DEC approval prior to discharge.

8.1.4 Emergency Absorption

This involves direction of effluent to the emergency absorption package. This package is an industrial scale activated carbon bed, which is highly effective at removing organics from water, until the carbon bed is

saturated, after which the bed must be replaced and disposed of to an appropriately licensed landfill. Once released to the emergency absorption package, water is discharged directly into the MUBRL.

This option is appropriate when:

- Small volumes of waste water require treatment for contaminants that the emergency absorption package is effective at removing (principally organics), where other alternatives have been exhausted and discharge is required; or
- Fast release of effluent is required to prevent escalation of an event (e.g. flooding etc) where the discharge specifications have not been achieved but alternative management options can not be initiated in time.

The emergency absorption package is unlikely to remove significant portions of other constituents, including metals and nutrients. The emergency absorption package is not a long term treatment solution nor can it treat large volumes of waste water with high levels of organics, as the bed will quickly deplete and require replacement. This will also generate solid waste for disposal.

8.1.5 Use for Dust Suppression/Irrigation

Where chemical composition of treated waste water meets appropriate criteria, treated waste water can be used for suppressing dust on either the Pluto site or other Woodside-operated sites. This would involve irrigation of effluent through either manual distribution (water carts) or Pluto Site B sewage irrigation piping. Criteria for the safe use of treated water onsite for irrigation/dust suppression are provided in Table 8-3.

Table 8-3 Discharge Limits for Onshore Irrigation / Dust Suppression

Parameter	Limit for Dust suppression
pH ¹	>6.0 and <9.0
E.Coli ²	<10 cfu/100mL
BOD ²	<20 mg/L
SS ²	<30 mg/L
Turbidity ²	<5 NTU
Nutrient Levels	Limit for Dust Suppression (mg/L)
Inorganic Nitrogen ³	30
Total Nitrogen ⁴	50
Reactive Phosphorus ³	7.5
Total Phosphorus ⁴	12
Metalloids	Limit for Dust Suppression (mg/L)
Arsenic ⁴	2
Chromium ⁴	1
Cobalt ⁴	0.1
Copper ⁴	5
Lead ⁴	5
Manganese ⁴	10
Mercury ⁴	0.002
Molybdenum ⁴	0.05
Nickel ⁴	2
Vanadium ⁴	0.5
Zinc ⁴	5
Oil & Grease	Limit for Dust Suppression (mg/L)
Oil & Grease ¹	10

This document is protected by copyright. No part of this document may be reproduced, adapted, transmitted, or stored in any form by any process (electronic or otherwise) without the specific written consent of Woodside. All rights are reserved.

Notes:

1. Criteria based on Appendix 6 of *Australian Guidelines for Sewerage Systems – Effluent Management* (ARMCANZ/ANZECC 1997) for Treatment Level C
2. Criteria based on *Guidelines for the Use of Recycled Water in Western Australia* (WA Health 2010).
3. Criteria based on *Water Quality Protection Note 22 - Irrigation with nutrient rich waste water* (WA Department of Water July 2008)
4. Criteria obtained from *Australian and New Zealand Guidelines for Fresh and Marine Water Quality: Volume 3 - Primary Industries – Section 4.2 – Water Quality for Irrigation and General Reuse (short term irrigation guidelines)*

Whilst this is in the contingency section, it also represents a viable alternative re-use of treated waste water. It does however require manual handling and, when distributed manually, use of heavy vehicles (with corresponding worker exposure and fuel use).

This option is appropriate when:

- Contaminant levels are below the criteria specified for irrigation and other constituent concentrations considered appropriate;
- Areas cleared for industrial purposes are available for irrigation (e.g. laydown areas);
- Irrigation will not cause surface run-off beyond the irrigation area; and
- A Recycled Water Management Plan covering the proposed activity is in place, approved by the Department of Health.

This option is not appropriate where the site is experiencing rainfall or rainfall is imminent, but is suitable at all other times where land is available. The option can not be used if the treated waste water does not conform to the specifications within Table 8-3 or other parameters of the treated waste water are considered unsuitable for irrigation.

8.1.6 Offsite Export to ToxFree or Alternative Treatment Facility

ToxFree operates a high temperature incinerator in Port Hedland that is used routinely by Woodside-operated facilities to safely dispose of liquid and solid wastes requiring specialised management and where material can not be cost-effectively recovered or re-processed. These facilities will likely be used to manage water from the initial separation elements of the ETP, to dispose of any recovered oily water or oil-contaminated sludges.

Incineration could be used to treat waste water that is well outside the discharge specification and where subsequent treatment of the waste water through other contingency options is unlikely to meet either onshore or offshore disposal specifications within a reasonable timeframe.

Any waste water managed using this approach will be transported to Port Hedland under the appropriate waste transportation licenses held by ToxFree and in accordance with the facility waste management plan.

Alternatively, other appropriately licensed transport and receiving facilities may be used.

8.1.7 Diversion of Non-Process Waste Water

Where non-process waste water is available, diversion of this water into the final inspection tanks may be appropriate to decrease the concentration of one or more constituents to achieve the discharge specification or diluted discharge specification.

This may be appropriate when non-process water is available, the non-process water to be added to the final inspection tanks contains little of the constituent(s) exceeding the discharge specification, alternative means

to treat the water for those constituents is not available (e.g. recycle through the MBR) and this represents the best contingency option available (when considering other viable contingency options).

This option is not suitable if the dilution volume required is greater than the volume remaining within one of the final inspection tanks. Only non-process waste water should be used for this (i.e. service water generated on site or supplied by third parties will not be used as a diluent).

8.1.8 Temporary Storage and/or Diversion of Uncontaminated Inflows

Several options for temporary storage on site exist, which can be implemented to provide hold-up. The first is through utilisation of one of the two final inspection tanks. Each tank has a capacity of approximately 860m³ and thus provides in the order of 24 days storage during periods of low flow and 30 hours storage in high flow periods.

High flow cases can be managed through careful management of AC drainage areas, including implementation of the site spill response procedure. Adherence to this procedure will result in AC first flush water being directed (following testing) to the EOF drainage system and to natural drainage lines, limiting stormwater flow to the effluent treatment plant. This may prolong the number of days storage available within a final inspection tank from 30 hours to between 5 and 20 days or possibly longer (depending on produced water rates).

Two other viable options exist to provide temporary storage of off-specification water, namely:

- Storage of water within the buffer condensate storage tank (total capacity 10,000m³); and
- Portable containers (capacity of up to 1,000m³ capable of being mobilised at relatively short notice).

Temporary storage of off-specification waste water in either the final inspection tanks or portable containers may be appropriate when short (days) to medium (months) storage of a small (less than 1,000m³) quantity of off-specification water is required, to allow for other contingency measures to be enacted (e.g. recycle through the MBR, dust suppression, export etc). It is unlikely to be suitable for storage of larger volumes. Use of a final inspection tank for longer term storage is also not appropriate, as it limits the operation of the remaining ETP system to one final inspection tank, decreasing operator flexibility to manage treated waste waters and deal with all operating scenarios.

Storage in the buffer condensate tanks may be suitable for duration of up to six months (depending on the time since last condensate off-take), however it has a direct impact on the condensate load-out process and, where water being stored is not oil-contaminated, will inevitably result in further contamination of the stored water through dissolvable hydrocarbon equalisation with any remaining condensate within the tank and during recovery from the tank and thus will require further treatment.

Storage does not provide any treatment and therefore this option is only appropriate where the ultimate disposal option just requires further time to implement.

8.1.9 Emergency Discharge

This contingency involves discharging any effluent within one or both of the final inspection tanks directly to the MUBRL (and to ocean), whether or not the discharge specification (either from the final inspection tank or following dilution within the MUBRL system) has been achieved.

There are very few scenarios whereby this contingency would require activation and is only appropriate where the influent flow rate to the final inspection tanks is in excess of the capacity of the emergency absorption package or other contingency options, otherwise the emergency absorption package or other contingency options will be implemented in preference.

This contingency will therefore only be instigated in the event of a system failure that threatens to overflow the final inspection tanks and other contingency measures can not be implemented.

If this contingency is activated, all practicable steps will be immediately activated to, in order of preference and at the earliest opportunity:

- halt emergency discharge;
- reduce the flow rate or flow quantity being discharged;
- implement other contingency options in parallel to either provide partial treatment of effluent being discharged (e.g. emergency absorption etc) or decrease the volume of effluent requiring discharge (e.g. temporary storage etc).

Any use of this contingency will be reported to the regulator in line with Section 7.3. Monitoring of effluent will still be undertaken in accordance with Table 6-1 to allow post-event analysis of compliance and/or allow risk assessment to be undertaken on the actual discharge.

8.2 Contingency Prioritisation

Subject to the parameters for implementation listed in Section 8.1, the preference for implementing a contingency measure to manage treated waste water outside the specifications is as follows. This is provided as general guidance only. For any given scenario, consideration of all factors may mean a “lower preference” option is selected.

Higher preference:

- Recycle through MBR
- Dilute through MUBRL
- Release to MUBRL following risk assessment
- Use for irrigation or dust suppression
- Use of emergency absorption package

Lower preference:

- Diversion of non-process waste water
- Offsite export to ToxFree or similar
- Temporary storage
- Emergency discharge

8.3 Outfall Modification

The MUBRL outfall is owned and operated by Water Corporation and a routine programme of dilution verification is undertaken by Water Corporation to ensure the diffuser is achieving its stated performance. The following contingency plan is directly quoted from the MUBRL Operational Environmental Management Plan (2010) and outlines the process for management of diffuser performance:

1. *If the dilution verification study indicates that the discharge is not achieving a minimum dilution of 1:86 at the [Low Ecological Protection Area] LEPA boundary or dilution is not sufficient to ensure that high ecological protection criteria are met at the edge of the LEPA, then the following course of action will be taken:*
2. *Identify the cause of difference between predicted and actual (the model, monitoring error, discharge rates or met-ocean conditions).*
3. *Re-assess the risk that the guidelines at the edge of the mixing zone will not be met. This may include remodelling the plume based on additional data.*

4. *Report on the outcomes to the EPA and the actions that will be taken. Depending on the risk posed, these actions may include:*
- *Additional field studies or monitoring;*
 - *Adjustments to process or flows;*
 - *Modifications to infrastructure; and./or*
 - *Independent review of issue and further consultation with EPA.*

9. REFERENCES

ANZECC/ARMCANZ (2000) *Australian and New Zealand Guidelines for Fresh and Marine Water Quality*.

Department of Environment (2006) *Pilbara Coastal Water Quality Consultation Outcomes: Environmental Values and Environmental Quality Objectives*, March 2006:

Department of Environment and Conservation (2010) *Assessment Levels for Soil, Sediment and Water, Contaminated Sites Management Series*, February 2010.

Water Corporation (2010) *Desalinated Water and Seawater Supplies Project, Burrup Peninsula, Performance and Compliance Report and Performance Review Report*, June 2010

Water Corporation (2010) *Burrup Peninsula Desalinated Water and Seawater Supplies Project Operational Marine Environmental Management Plan*, prepared by Oceania Consulting Pty Ltd, September 2010

Woodside (2006) *Pluto LNG Development - Draft Public Environment Report / Public Environmental Review, EPBC Referral 2006/2968, Assessment No. 1632*.

Woodside (2010) *Pluto LNG Project Effluent Treatment Plant Commissioning Plan*

APPENDIX A – SUMMARY OF PROJECT COMPLIANCE WITH MINISTERIAL STATEMENT NO. 757 CONDITION 7-1, 7-5 TO 7-7

Deepwater Marine Outfall Conditions under Ministerial Statement No. 757		Compliance Status
7-1	If a marine wastewater discharge is required by the proponent, the proponent shall construct the associated infrastructure so that wastewater is discharged into water of depth greater than 30 metres outside the Dampier Archipelago, unless otherwise determined by the CEO under Part V of the Act.	A Works Approval for an effluent treatment plant and associated discharge of treated effluent through the MUBRL was issued on 9 September 2009 (W4466/2008/1). Woodside has invested in best practice waste water treatment technology to ensure that treated waste water discharges are of the highest standard practicable.
7-5	<p>Prior to submitting a Works Approval application for the wastewater treatment plant, the proponent shall:</p> <ol style="list-style-type: none"> 1. characterise in detail the physical and chemical composition and flow rates of all wastewater streams within the site and, using the toxicity of mixtures principles, predict the theoretical toxicity of the combined wastewater after treatment; 2. determine, for all contaminants and nutrients, the total annual loads of contaminants and nutrients in the wastewater discharge exiting the site; and 3. determine, for normal and worst-case conditions, the concentrations of contaminants and nutrients (for agreed averaging periods) in the wastewater discharge exiting the site. 	<p>Characterisation of the physical and chemical composition of the expected waste streams and their theoretical toxicity has been determined and included within the application for a Works Approval. For all contaminants (including nutrients) expected, total annual loads have been estimated and normal and maximum contaminant concentrations estimated.</p> <p>This is supported by the Effluent Treatment Plant Commissioning Plan, which defines a wider range of effluent concentrations during the start-up and commissioning phase, whilst equipment and biological processes within the facilities are acclimatised and the system fully commissioned.</p>
7-6	Prior to submitting a Works Approval application for the wastewater treatment plant, the proponent shall demonstrate that the wastewater discharge will meet “best practicable technology” and waste minimisation principles for contaminants and nutrients.	The Works Approval application provided detail of how the waste water treatment plant has met or exceeded the requirements for “best practicable technology” and waste minimisation principles for contaminants and nutrients. Refer Works Approval 2008/4444/1.
7-7	<p>Prior to submitting a Works Approval application for the wastewater treatment plant, the proponent shall design, and subsequently operate, plant and equipment on the site such that:</p> <ol style="list-style-type: none"> 1. the contaminant concentrations in the wastewater effluent from the site, just prior to entry to the wastewater discharge system, meet (in order of preference): <ul style="list-style-type: none"> • the ANZECC/ARMCANZ (2000) 99% species protection level; or • the ANZECC/ARMCANZ (2000) 99% species protection level at the edge of an approved mixing zone; 2. the concentrations of contaminants in the wastewater effluent which can potentially bio-accumulate / bio-concentrate meet the ANZECC/ARMCANZ (2000) 80% species protection trigger levels just prior to entry into the wastewater discharge system; and 3. mass balances and inventories of toxicants can be maintained throughout the life of the plant so that their fate can be traced. 	<p>The plant has been designed to reliably meet ANZECC/ARMCANZ (2000) 99% species protection levels at the edge of an agreed mixing zone and 80% species protection level just prior to entry into the waste water discharge system for all parameters (not restricted to those with the potential to bio-accumulate) against the level of dispersion and dilution achieved at the MUBRL diffuser location</p> <p>Waste water testing during the operational phase of the facilities (detailed within this plan) will enable mass balances and inventories of different species of chemical to be determined as required.</p>

This document is protected by copyright. No part of this document may be reproduced, adapted, transmitted, or stored in any form by any process (electronic or otherwise) without the specific written consent of Woodside. All rights are reserved.

APPENDIX B – RISK ASSESSMENT TEMPLATE

This document is protected by copyright. No part of this document may be reproduced, adapted, transmitted, or stored in any form by any process (electronic or otherwise) without the specific written consent of Woodside. All rights are reserved.

Controlled Ref No: XA0000AH0029

Revision: 0

Native file DRIMS No: 5717026

Page 53 of 57

Uncontrolled when printed. Refer to electronic version for most up to date information.

PLUTO LNG PROJECT TREATED WASTE WATER DISCHARGE RISK ASSESSMENT APPROVAL

1. Application Details

Date of Application		Contact Person	
Date of Proposed Discharge		Position	
Quantity (kL)		Email	
Discharge Duration (hrs)		Phone	
Last Discharge Subject to Risk Assessment (Detail)			

2. Details of Proposed Discharge

Known contaminants of concern exceeding specification:

3. MUBRL Operational Status

Outline the operational status of MUBRL on the proposed date of discharge:

4. Justification for Discharge

Outline reason for the discharge, eliminating alternatives to achieve the specification:

5. Risk Assessment

Assessment against discharge specification, ANZECC/ARMCANZ and recent WET test results and the Objectives as outlined in the TWMP. Consider mitigating factors (tide, MUBRL operation etc).

Risk assessment outcome	Consequence	Likelihood	Risk
(Use Woodside Risk Tables)			

6. Conditions of Discharge

List any conditions that underpin the Risk Assessment or that must be adhered to during discharge (e.g. discharge around high tide etc)

7. Authorisation

	Name (Print)	Position	Signature	Date
Woodside				
Department of Environment and Conservation, Pilbara Region				

This document is protected by copyright. No part of this document may be reproduced, adapted, transmitted, or stored in any form by any process (electronic or otherwise) without the specific written consent of Woodside. All rights are reserved.

APPENDIX C – PROPOSED DISCHARGE CRITERIA SUBJECT TO WET TEST OUTCOMES

Chemical or Chemical Group	Discharge Limit Conc.	Unit	Frequency	Reason for Inclusion in list of contaminants or stressors “of interest”
Operational Monitoring for Toxicants				
Aromatic and Polyaromatic Hydrocarbons	HOLD ¹	mg/L	Online: TOC analyser	Aromatic hydrocarbons, some derivatives of which are known from previous produced water studies to present the group of components likely to contribute to overall toxicity. Polycyclic aromatic hydrocarbons have been documented in numerous studies on the toxicity of naturally occurring and partially refined hydrocarbons to present the group of components most likely to govern overall toxicity.
	5	mg/L	Batch / field laboratory for first year of operations Quarterly / Pluto laboratory HORIBA free and dissolved hydrocarbon and TOC analysis	
			Annually / third-party NATA-accredited laboratory Speciated aromatic and PAH testing, concurrent with WET testing	
Activated Methyl-Diethanol Amine (aMDEA)	17	mg/L	Quarterly / Pluto laboratory Test for aMDEA Annually / third-party NATA-accredited laboratory Test for aMDEA	Water soluble process chemical, with slight to low toxicity to aquatic organisms. Storage on site may result in higher concentrations being accidentally discharged into the effluent treatment plant.
Mercury	1.4	µg/L	Quarterly / Pluto laboratory Test for Mercury Annually / third-party NATA-accredited laboratory Test for Mercury	Mercury is bio-accumulating in organisms and can be present in hydrocarbon streams. Whilst not immediately toxic at very low levels, potential for accumulation in the food chain makes this a constituent requiring monitoring. <i>It is noted that mercury removal beds are provided at the plant which is highly effective at removing mercury to very low levels.</i>
Operational Monitoring for MUBRL Compliance				
Temperature ²	±5	°C	Online temperature meter, correlated to WC background seawater readings monthly	Compliance with Ministerial Statement 594
	±2	°C		
Salinity (Total Dissolved Salts - TDS)	55,000	mg/L	Online metering, recorded continuously during discharge	
Oxidising Biocide	0.1	mg/L	Online metering, recorded continuously during discharge using free chlorine meter	
Antiscalent	2	mg/L	Annually / third party NATA-accredited laboratory	

¹ TOC limit to be calibrated following initial WET test and full-suite compositional analysis, which will enable determination of an appropriate TOC limit accounting for the various TOC components expected in the discharge (including MEG, aMDEA, total petroleum hydrocarbons including aromatic and poly-aromatic fractions etc).

² Temperature of discharge not to be more than 5°C above receiving water (background) temperatures. Temperature to not exceed 2°C above background levels for more than 20% of the time.

The list of chemicals or environmental stressors and their corresponding discharge limits will be reviewed following completion of the initial and annual WET tests and characterisation of discharged water and may be modified if required (refer Section 1.4) via the annual Licensing process under Part V of the *Environment Protection Act 1986*.